

The how-to magazine of electronics...

AN INTERTEC PUBLICATION
TM

ELECTRONIC

Servicing & Technology

NOVEMBER 1988/\$2.50

A homemade desoldering system • Troubleshooting IC regulators

Power conditioning: Protecting your electronics investment

**Computer servicing:
Troubleshooting cable-related
problems**



Intermittents. We Hear You.

Introducing The Heavy-Duty DMM With An Audible Readout That Lets You Keep Both Eyes On The Job.

Intelligent design and solid construction make the new HD 150 Series the best DMMs in their class.

They're the latest in a distinguished line that began when Beckman Industrial pioneered heavy-duty DMMs with their distinctive yellow color. Many competitors have since imitated that color. As for imitating their performance, no one comes close.

The HD 150 Series attains new levels of excellence with a range of advanced features. They're waterproof. Drop proof.

Auto-ranging. Slim-styled for one-hand comfort and convenience. With auto-off to prolong battery life. Plus 2 fuses, PTC resistor and MOV for unsurpassed overload protection.

Audible readout. A "sound" reason to go with the HD 150 Series. With this unique feature on the HD 153, you measure parameters by listening to a continuous variable tone. As the parameter you measure rises or falls, the tone's frequency increases or decreases, accordingly. Use it for volts, amps, or ohms. It's ideal for peaking and nulling, too.

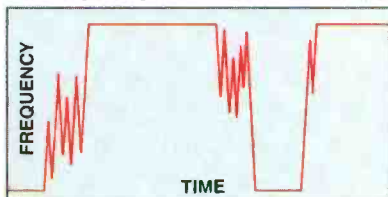

Intermittent alert. A key application of audible readout. The HD 153 pinpoints intermittents by emitting a "crackling" sound when they're detected. The response sounds in about 1 msec—far faster than the information appears on any DMM display.

Logic function.

The HD 153 detects TTL or CMOS logic pulses using standard test leads.

Easy to use.

The HD 150 Series lets you read the LCD even at wide angles. With the large rotary dial you select functions with one-handed (right or left) convenience. Auto-ranging speeds you to the right range. A tilt-stand and Skyhook let you set or hang the DMM almost anywhere.

Built tough to work hard. The HD 150 Series DMMs are so tightly sealed against water and grime that they're *guaranteed for five years* against contamination. And, because they're built so tough, they're guaranteed for two years against *any* damage (except abuse). Crashes, overloads, moisture, dust... you name it. The HD 150 Series can handle it all!

Listening is believing. For a hands-on demo, see your distributor now. Learn why the HD 150 Series is the soundest DMM value you'll see. Or hear.

Key Specifications

	HD 151	HD 152	HD 153
Auto-ranging	✓	✓	✓
Range Lock		✓	✓
Audible readout			✓
Tilt Stand and Skyhook™	Optional	Optional	Included
Logic pulse detector			✓
DC voltage accuracy	0.7%	0.5%	0.25%
10A range		✓	✓
Suggested list price	\$149.00	\$169.00	\$199.00



Beckman Industrial™

Beckman Industrial Corporation
Instrumentation Products Division
A Subsidiary of Emerson Electric Company
3883 Ruffin Road, San Diego, California 92123-1898
(619) 495-3200 • FAX: (619) 268-0172 • TLX: 249031

*In Service
Instruments,
We're The One.*

© 1988 Beckman Industrial Corporation
Specifications subject to change without notice.
Valox is a registered trademark of General Electric Corporation

Circle (1) on Reply Card

www.americanradiohistory.com

IT'S A
\$41 BILLION
INDUSTRY
AND THERE'S A SHARE
TO SPARE...
IF
YOU'RE
THERE.

Zero-In On Your 1989 Market At Winter CES.

The Consumer Electronics Show is the only way you can keep up with everything that's happening—non-stop—in consumer electronics.

The Products. Audio, video, furniture, photographic equipment and accessories; mobile electronics, car audio, cellular and security; telephones, TADs and accessories; home office; educational/recreational hardware and software; prerecorded video software; watches and personal electronics; specialty audio. That's a lot to keep up with. But there's more.

Sources. Marketing and merchandising. Price-points and margins. Competition.

News. Stories. Trends. Promotions that worked, or fizzled. Personal experiences. And still more.

The People. Nearly 25,000 representing 1,350 exhibiting companies. Often they're the real reason why you buy from one company and not another. Even when products and pricing are identical. CEOs and Presidents; Sales, Marketing, Credit, and Advertising Managers. And the company images they project.

The Winter CES.* It tells you how to be a prophet, and how to turn one, at the same time.

Register Now! Save the \$25 On-Site Fee. Get exclusive discounted airfares—call American Airlines, 1/800-433-1790 or CW Travel, 1/800-524-4433 and identify yourself as a Winter CES traveler.

For Exhibitor Information please call or write: Consumer Electronics Shows Exhibit Sales, Temporary Headquarters, 1722 Eye Street, NW, Suite 200 Washington, DC 20006 USA

1989 International Winter Consumer Electronics Show.* Saturday, January 7 through Tuesday, January 10 Las Vegas, Nevada USA

For the trade only. No one under 18 years of age will be admitted. Over-the-counter sales are not permitted.

Pre-register Now. Take advantage of the advance complimentary registration and save the \$25 on-site fee.

Mail this completed form to Consumer Electronics Shows, c/o CompuSystems, Inc., P.O. Box 6579, Broadview, IL 60153-6579.

To obtain your badge by mail, we must receive this form no later than Thursday, December 15. **Attach your business card for proper verification and prompt processing.** If we receive this form after December 15 and before December 28, 1988, you may pick up your badge at the "Advance Registration Pick-up Desk," after showing two forms of ID, in the main registration area of the Las Vegas Convention Center, West Hall, the Hilton Hotel, Sahara and Riviera Hotels. Registration Forms received after December 28 will not be processed. Please register on-site after paying \$25.00.

To register more than one qualified individual, please duplicate this Advance Registration Form and attach business cards. Complete Show information, including housing form, will be sent separately.

**1989 International Winter Consumer Electronics Show*
Saturday, January 7 through Tuesday, January 10, 1989
Las Vegas, Nevada USA**

*Name _____
Company _____
Street _____
City _____ State _____ Zip _____
Phone _____
Last four digits of your Social Security # (for internal use only) _____

*Only 21 characters including spaces will appear on your badge.

Please check **only one** badge category:

- 1 Retailer
- 2 Distributor
- 3 Dept./Chain Store Buyer
- 4 Prem./Catalog Buyer
- 5 Manufacturer's Rep
- 6 Manufacturer
- 7 Institutional Buyer
- 11 Adv./Mktg./PR/Consultant
- 12 Financial/Market Analyst



The Consumer Electronics Shows are sponsored and produced by the Electronic Industries Association Consumer Electronics Group.

Circle (3) on Reply Card

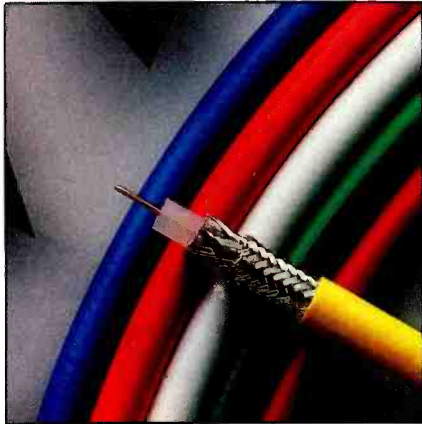

Page 10

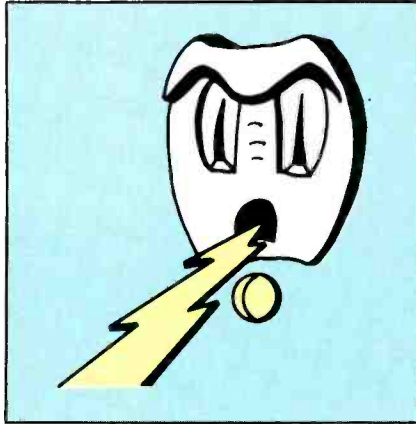

Page 18



Page 22

FEATURES

10 Computer servicing: Troubleshooting cable-related problems

You may not think you need to be a cable expert to service personal computers, but using the wrong kind of cable or cables that are too long can cause data errors. Here's the latest information on RS-232D, the EIA's recent revision on cable-length standards.

18 Power conditioning: Protecting your electronics investment

If you've ever been in a computer-oriented office during a thunderstorm, you probably know what that chorus of dismay means when lightning hits the transformer down the street—a lot of work down the drain. But installing power-conditioning equipment isn't the whole answer. You have to choose the right stuff and know how to install it properly.

22 A homemade high-vacuum desoldering system

By William L. Call
A vacuum-powered hollow-tip iron

may be the Cadillac of solder-suckers, but there's a simple homemade recipe any servicer can follow. Just take one vacuum pump, add one hollow-tip iron, some assorted fittings and connectors, and you have one easy, do-it-yourself vacuum desoldering system.

46 Troubleshooting low-voltage IC regulators

By Homer L. Davidson

Just when you think you've seen it all, along comes a 3-lead device in the low-voltage power supply. It can't be a transistor, so what is it? These pseudo-transistor regulators, or linear IC low-voltage regulators, were used extensively in many foreign-built portable TV receivers between 1982 and 1987. Here's an explanation of what's inside them and how to test them.

DEPARTMENTS

4 Editorial

6 News

16 Test your electronics
knowledge

17 Feedback

28 Technology
Taking your VCR with you

31 Profax

42 What do you know about electronics?

The Norton generator

45 Literature

53 Books

54 Products

56 Audio corner

Servicing the compact disc player—
Part II

58 Video corner I

Noise in the picture on playback

60 Video corner II

Elements of video optics—Part IV

62 Computer corner I

Interfacing computers to the analog
world—Part VI

64 Computer corner II

Clean me!

66 Readers' exchange

68 Advertisers' index

ON THE COVER

Installing and maintaining electronics products often requires some knowledge of fields that appear to have little connection. Connection, however, is the key word—The cable connecting a computer to its power source and its peripherals can be the cause of some PC failures.

LEADER



LCR

LCR-745G automates your LCR measurements.

Leader's LCR-745G auto-ranging, digital LCR Bridge tests components, sub-assemblies and systems completely automatically. Since it interfaces with standard GPIB systems, just plug it into your network and all functions operate under computer control. Compatible with virtually all test systems, the LCR-745G is a "listener/talker" that receives directions from your controller and supplies it with all the data needed to collect, record and analyze measurements.

Fast, easy-to-use and affordable.

The 745G is one of the least expensive automatic bridges with GPIB capability. Yet it is ideal for applications where ease of operation and high throughput are necessary. No wasting time on repetitive set-ups. The LCR-745G provides automatic resistance, capacitance and inductance measurements of both series and parallel circuits with Quality (Q) or Dissipation factor (D) displayed simultaneously.

The affordable way to bridge the LCR/GPIB gap.

Unparalleled accuracy and performance.

Even minute residual resistance, capacitance or inductance of the test leads won't be tolerated by the LCR-745G. Leader's offset function compensates for test lead error, normalizes the value of a component under test to zero, or references it to a standard. Two test frequencies permit highly accurate measurements, including those of usually hard-to-test electrolytic capacitors.

Brains and brawn.

Leader's 745G is built "tough" to withstand 3-shift production and

GPIB

rough use. It is backed by the Leader two-year warranty and coast-to-coast factory service.

Shop. Compare. You may discover Leader's 745G is not only the affordable way to bridge the LCR GPIB gap; it is the best way.

Call toll-free
(800) 645-5104

In N.Y. State
(516) 231-6900

Request an evaluation unit, our latest test equipment catalog, the name of your nearest "Select" distributor, or additional information.

For professionals

who know the difference.

LEADER
Instruments Corporation

380 Oser Avenue
Hauppauge, New York 11788

Regional Offices:
Chicago, Dallas, Atlanta,
Los Angeles, Boston.
In Canada call Omntronix Ltd.
(514) 337-9500

For Information Circle (4) on Reply Card For Demonstration Circle (23) on Reply Card

Once more with enthusiasm

There's a special kind of feeling about being a servicing technician, isn't there? It's a job with a high degree of challenge and, at the same time, a high degree of reward. Someone brings you an ailing TV, VCR, stereo amplifier, personal computer or whatever, and you set it on the bench, put it through some preliminary checks, then pull out the diagnostic equipment and go to work.

You don't even think about exactly what it is you're doing, but it consists, initially, of searching through the files in your own brain and comparing what you've observed in this case to what you have filed away. When you get to the point where the data available is not sufficient, you go to another source: the manufacturer's service data, perhaps a Sams Photofact, maybe an article from **ES&T**. The whole process is somewhat mysterious. Sometimes it proceeds in a straight line from a concrete description of symptoms to a hypothesis of the problem; sometimes it proceeds in a series of fits and starts.

The experience must be somewhat like that felt by a doctor when he's diagnosing an illness, or a mechanic when he's trying to determine why that engine is running rough. And the feeling you get when you've made the diagnosis and fixed the problem—it's like a combination of solving a puzzle and winning the grand prize.

It's interesting to note the different kinds of personalities. There are those types of people who, when faced with something that doesn't work, roll up their sleeves, scratch their heads and try to find out what's wrong and how to fix it. Then there are the types who, when something goes wrong, wrinkle their nose like something smells bad and immediately call "someone" to fix it. It's the difference between someone who looks on a product as nothing more than a device to fulfill some function and someone who looks at a product as an end in itself.

For example, when television first came out, there were those who heralded it as a new method of communications. They didn't care how it worked or what it involved, they merely knew

that it could transmit pictures and sound over many miles and, as such, would make a great way to convey information. Ultimately, of course, it became the great entertainment medium it is. To substantial numbers of people, however, it was more than just a tool. It was a fascinating technology in and of itself, and they wanted to find out just how it works and what they could make it do; these were the types of people who became TV servicing technicians.

The same is true of other modern technologies. When it became clear that personal computers were a developed technology, there were those that saw them as tools for business forecasting, word processing, establishing an electronic filing cabinet or any of a number of other applications. These people saw computer technology itself as almost trivial: It was the applications it could perform that made it worthwhile. On the other hand, the technically oriented types found the technology fascinating and wanted to learn more, not only about what the computer could do, but how it did it.

In the computer world, it was these technically curious individuals who became the computer engineers, systems analysts, programmers and servicing technicians.

When something quits working, then, it's not surprising that the type of people who are interested enough in a technology to want to know how it works are the same type of people who find it a challenge to pinpoint the problem and make the product work like new again.

And, when faced with a servicing problem in one of today's complex consumer-electronics products, somehow there's nothing quite as satisfying as knowing enough about the technology to not only operate the product, but to restore it to operation. In a world that has become almost intolerably complex to most people because of all these difficult to understand electronic marvels, the electronic servicing technician is in a uniquely comfortable position.

Nile Conrad Perren

Good as Gold

FLUKE
1,000,000



The 70 Series Multimeters: the shining standard by which others are measured.

These multimeters are produced through advanced technology that assures you a wealth of product features. Giving you solid value for your money.

Security of a 3-year warranty.

A 3-year warranty reduces your cost of ownership. So you don't have to pay the price over and over for lesser-quality multimeters.

More features for your money.

Choose from either the basic 73 or the feature-rich 75 and 77. You'll find the features you need at the price you can afford. Touch Hold™ for capturing and holding readings. Audible tones to signal you for continuity. Autoranging for simple operation. And a sleep mode for extending battery life up to 2000 hours.

Extra protection built in.

Features built into every 70 Series multimeter help ensure your safety and protect the meter, too. High-energy fuses on all current inputs, including the 10A range. Overload protection. An ABS plastic case, and a protective holster (77 only) that guards your meter against bumps and jolts.

Made in the U.S.A.

Like other Fluke products these multimeters offer you uncompromised quality at competitive prices. So get your hands on a 70 Series Multimeter at leading electronics distributors nationwide. Or, call toll free **1-800-44-FLUKE, ext. 33** for a free brochure.

FROM THE WORLD LEADER
IN DIGITAL MULTIMETERS.

FLUKE 73, 75, 77

\$79, \$119, \$149	2000+ hour battery life
0.7%, 0.5%, and 0.3% basic dc accuracy	3-year warranty
Analog/digital display	Audible continuity (75 & 77)
Volts, ohms, 10A, diode test	Range hold (75 & 77)
Fused current inputs	Touch Hold function (77)
Autorange	Multipurpose holster (77)

FLUKE®

Circle (5) on Reply Card

NARDA announces association

The National Association of Retail Dealers of American (NARDA) has announced the formation of a new association, the Service Contract Industry Council (SCIC), for companies that provide administration for product service contracts. The purpose of the association, which will be a subsidiary of NARDA, is to establish standards for the service contract industry. For more information, contact David Ashton at NARDA, 10 E. 22nd St., Suite 310, Lombard, IL 60148; 312-953-8950.

NPEC discusses training materials

The need for textbooks and training manuals to keep up with a rapidly changing technology was a key issue discussed at the Instructors Conference at the National Professional Electronics Convention (NPEC), Aug. 1-6. Suggestions included adding lesson plans and text material to technical seminars at the convention and integrating studies from vo-tech high schools, trade schools and 4-year colleges. Plans were made to award Continuing Education Units for applicable programs during the 1989 convention, which will be held Aug. 6-12 at Loews Ventana Canyon Resort, Tucson, AZ. For more information,

contact the NPEC at 2708 W. Berry, Fort Worth, TX 76109; 817-921-9101.

UL proposes antenna standard

Underwriters Laboratories is proposing the updated Standard for Safety for Antenna Rotators, UL 150, for recognition as an American National Standard. UL 150 covers antenna rotators intended for household and commercial use on supply circuits. It does not cover systems that use a stationary antenna and change the receiving pattern by electronic or switching means. UL 150 is a revised version of ANSI/UL 150-1984, which is currently recognized by the American National Standards Institute (ANSI). For a free copy or to send comments, contact L.M. Cohen at UL, 333 Pfingsten Road, Northbrook, IL 60062-2096; 312-272-8800, ext. 2692.

Philips ECG offers gift certificates

Philips ECG is awarding gift certificates from Philips ECG, MacDonalds and K-Mart for users of ECG semiconductors, tripler devices and surge suppressors. The minimum redemption is \$5 and must be redeemed by Jan. 13, 1989. For more information, contact the company at 617-890-6107.

EIA/CEG schedules 1989 VCR workshops

The Electronics Industry Association/Consumer Electronics Group (EIA/CEG) is offering a series of VCR servicing workshops designed to train and upgrade currently employed consumer electronics technicians. The 40-hour, 5-day workshops

will be conducted by EIA-trained instructors at the following locations.

For more information, contact the EIA/CEG at 2001 Eye St. N.W., Washington, DC 20006; 202-457-4919.

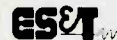

Locations	Dates
Video Technical Institute 1806 Royal Lane Dallas, TX 75229	March 20-24 July 31-Aug. 4 Nov. 6-10
United Electronics Institute 3924 Coconut Palm Drive Tampa, FL 33619	Sept. 26-30 March 27-31 June 26-30 Sept. 25-29
Illinois Technical College 506 S. Wabash Ave. Chicago, IL 60605	May 1-5 Aug. 28-Sept. 1
Video Technical Institute 2828 Junipero Ave. Long Beach, CA 90806	Aug. 1-5 Nov. 14-18 May 15-19 July 31-Aug. 4 Oct. 9-13

The how-to magazine of electronics...

ELECTRONIC

Servicing & Technology

Electronic Servicing & Technology is the "how-to" magazine for technicians who service consumer electronics equipment. This includes service technicians, field service personnel and avid servicing enthusiasts who repair and maintain audio, video, computer and other consumer electronics equipment.

EDITORIAL

Nils Conrad Persson, *Editor*
Carl Babcock, *Consumer Servicing Consultant*
Tom Cook, *Senior Managing Editor*
Alisa Carter, *Associate Editor*
Pamela S. Fleener, *Editorial Assistant*

CONSULTING EDITORS

Homer L. Davidson, *TV Servicing Consultant*
Christopher H. Fenton, *Circuit Fabrication Consultant*
Victor Meeldijk, *Components Consultant*
Kirk G. Vistain, *Audio Consultant*
Sam Wilson, *Electronics Theory Consultant*

ART

Kevin Callahan, *Creative Director*
Barbara Miles, *Graphic Designer*

BUSINESS

Cameron Bishop, *Group Vice President*
Eric Jacobson, *Publisher*
Greg Garrison, *Sales Manager*
Stephanie Hanaway, *Promotions Manager*
Kelly Hawthorne, *Promotions Coordinator*
Dee Unger, *Advertising Business Manager*
Catherine Grawe, *Advertising Coordinator*

ADVERTISING

Regional advertising sales offices are listed in classified pages.

ADMINISTRATION

R.J. Hancock, *President*
Doug Reimer, *Circulation Vice President*
Jane J. Powell, *Circulation Director*
Jo Ann DeSmet, *Fulfillment Manager*
Barbara Clare, *Reader Correspondent*



Member, Audit Bureau
of Circulation



Member, American
Business Press



Member, Electronic
Servicing Dealers
Association

CORRESPONDENCE

Editorial, advertising and circulation correspondence should be addressed to: P.O. Box 12901, Overland Park, KS 66212-9981 (a suburb of Kansas City, MO); 913-888-4664. Home office fax: 913-888-7243. Home office telex: 42-4156 INTERTEC OLPK

SUBSCRIPTION PRICES: one year, \$19.49; two years, \$32.98 in the USA and its possessions. Foreign countries: one year, \$23.49; two years, \$36.98. Single copy price: \$2.50; back copies, \$3.00. Adjustment necessitated by subscription termination to single copy rate. Allow 6 to 8 weeks for new subscriptions.

PHOTOCOPY RIGHTS: Permission to photocopy for internal or personal use is granted by Intertec Publishing Corp. for libraries and others registered with Copyright Clearance Center (CCC), provided the base fee of \$2 per copy of article is paid directly to CCC, 21 Congress St., Salem, MA 01970. Special requests should be addressed to Eric Jacobson, publisher. ISSN 0278-9922 \$2.00 + 0.00

Electronic Servicing & Technology (ISSN 0278-9922) is published monthly for \$19.49 per year by Intertec Publishing Corp., 9221 Quivira Road, Overland Park, KS 66215. Second-class postage paid at Shawnee Mission, KS and additional mailing offices. POSTMASTER: Send address changes to ELECTRONIC SERVICING & TECHNOLOGY, P.O. Box 12960, Overland Park, KS 66212.

©1988 All rights reserved.



Service market penetration. Times two.



MSM magazine delivers the computer service industry's buyers—32,000 service managers.

ES&T magazine delivers the consumer electronic service industry's buyers—43,000 service professionals.

Together, they round out your market penetration to the entire service industry spectrum.

And here's the best part of this ideal media mix: Generous combination frequency ad rate discounts mean twice the market reach for you...at substantially reduced rates in both magazines!

Why settle for only half of your marketing potential? Put your advertising on double-duty in MSM and ES&T... **and increase your sales to the entire service industry.**

Call (913) 888-4664 for more information.

P.O. Box 12901, Overland Park, KS 66212 (913) 888-4664 Fax: (913) 541-6697

An affordable portable i

Price/Bandwidth

	\$4995	100 MHz 2230 DSO*	20 MS/s, 4K Record Length, 100 ns Glitch Capture, Cursors, CRT Readout, GPIB or RS-232-C Option
	\$3995	60 MHz 2221 DSO	20 MS/s, 4K Record Length, 100 ns Glitch Capture, Cursors, CRT Readout, GPIB or RS-232-C Option
	\$2995	60 MHz 2220 DSO	20 MS/s, 4K Record Length, 100 ns Glitch Capture, GPIB or RS-232-C Option
	\$2995	100 MHz 2236 Two Channel	Counter/Timer/DMM, Dual Time Base
NEW	\$2795	100 MHz 2247A Four Channel	Counter/Timer, Store/Recall of 20 Front Panel Setups, Auto Setup, Smart Cursors™
	\$2395	100 MHz 2246A Four Channel	Store/Recall of 20 Front Panel Setups, Auto Setup, Smart Cursors™, Dual Time Base
	\$2395	50 MHz 2210 DSO	20 MS/s Sample Rate, 4K Record Length
NEW	\$1495	20 MHz 2201 DSO	10 MS/s Sample Rate, 2K Record Length, Hard Copy (RS-232-C) Option
	\$1795	100 MHz 2245A Four Channel	Auto Setup, Cursors, Dual Time Base
	\$1595	100 MHz 2235 Two Channel	Dual Time Base
	\$1095	50 MHz 2225 Two Channel	Horizontal Magnification (x5, x10, x50)
	\$695	20 MHz 2205 Two Channel	

*Digital Storage Oscilloscope

\$695.

Check the prices and performance. You'll find the best measure of both in Tek 2200 Series Oscilloscopes. Twelve scopes with bandwidths ranging from 20 to 100 MHz. Two and four channels. Analog and digital. And prices starting at just \$695.

Select for such features as automatic setup, time and voltage cursors, built-in DMM functions, Counter/Timer and dual analog/digital capabilities at the push of a button.

These are scopes you'll appreciate for their well-proven reliability, achieved through simplified, practical internal design. They come

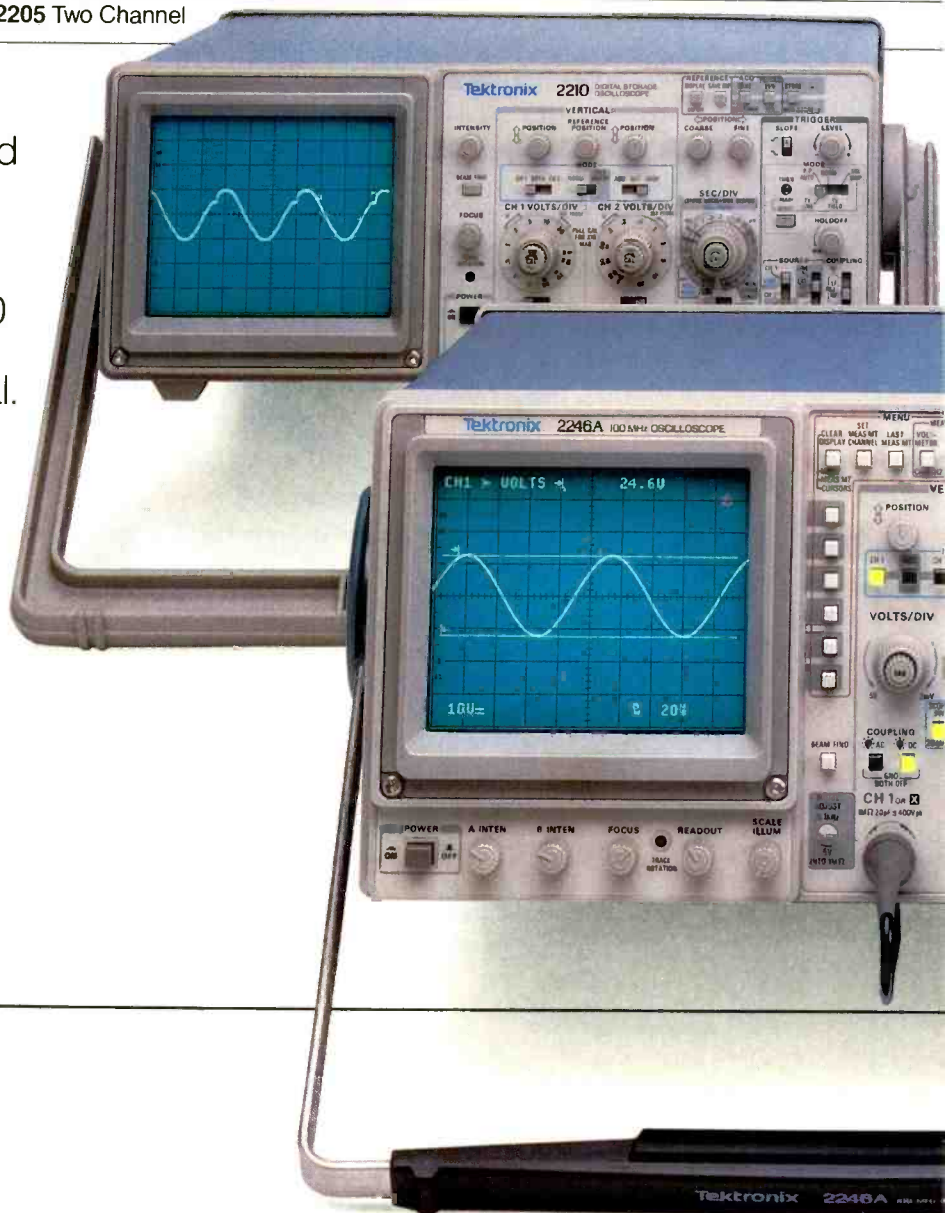

right within your range.

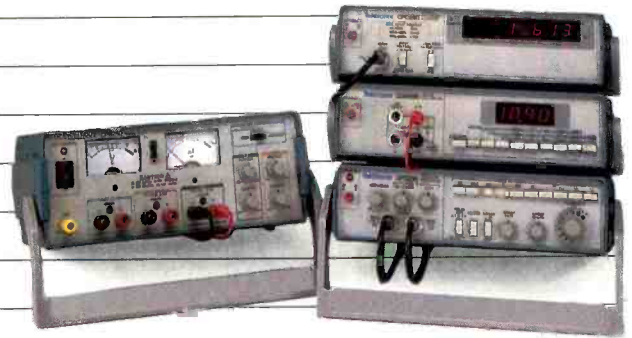

Industrial-quality test instrumentation starting at \$295.



complete with probes and comprehensive Tek warranty that includes the CRT.

Ask those who own, use and rely on one—on the bench or in the field. There's just no substitute for genuine Tek quality. At any price. And at these prices, all the better.

Order one to go. Ask your Tek representative to set up a demo. Or call Tek direct. No need to settle for less when there's a top quality Tek portable with performance and price right within your range.

LISTED



For easy ordering or more information, call Tek direct:

1-800-426-2200



Tektronix
COMMITTED TO EXCELLENCE

Circle (6) on Reply Card

Computer servicing:

Troubleshooting cable-related problems

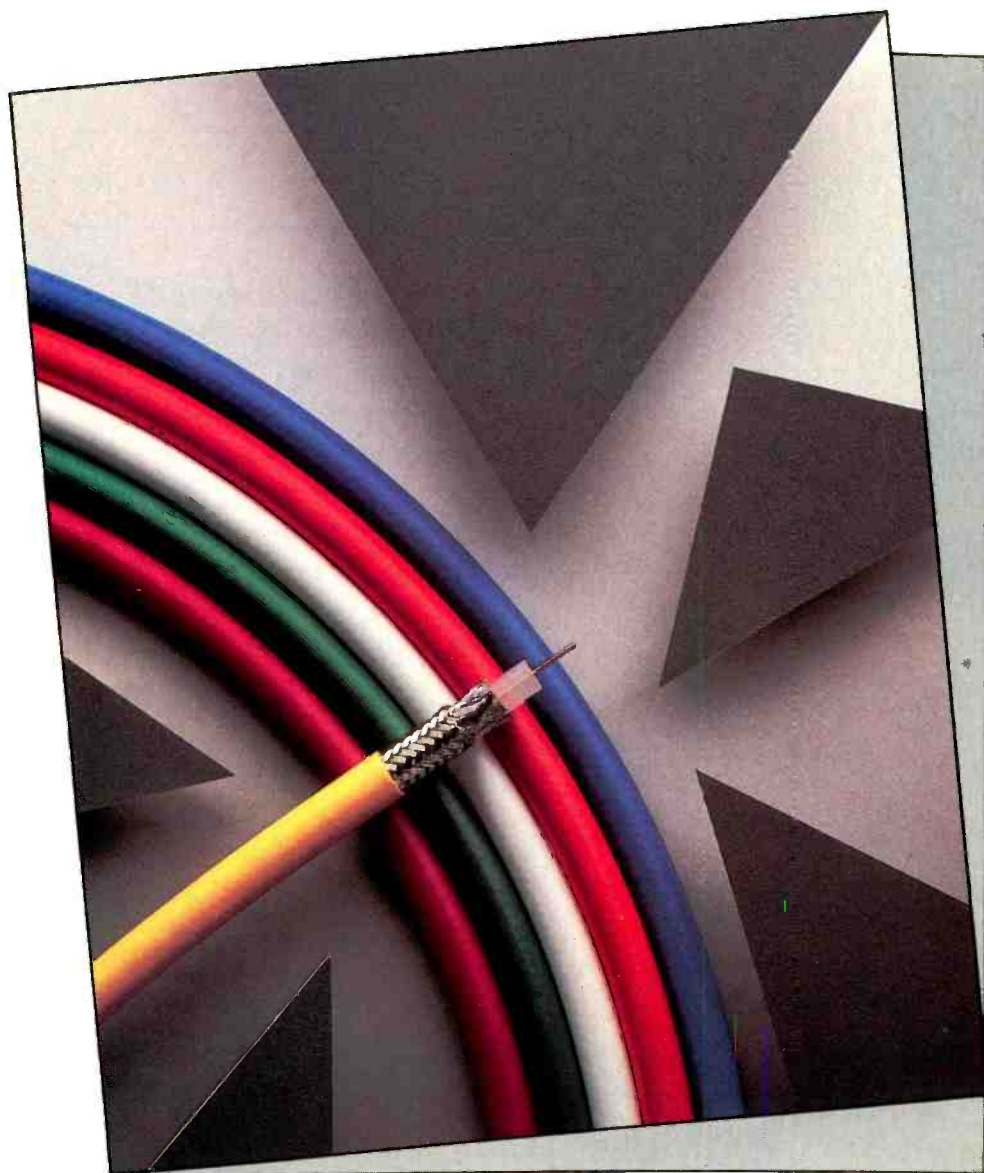

When you're servicing a personal computer, it's important to be aware that problems such as data errors may occur if the wrong kind of cable is used or if the cables are too long. This article describes test results that will help determine the maximum length of cable you can use without incurring errors.

People who service computer systems that are based on the Electronic Industries Association (EIA) recommended standard RS-232 interface need to know the maximum acceptable cable length for the different applications they deal with. RS-232-C recommends limiting the cable length to 50 feet or less, but it does allow the cable to exceed 50 feet as long as the total capacitance is less than 2,500pF.

A recent revision, RS-232D, does not specify a maximum cable length but does specify a maximum of 2,500pF for the receiving end of the interchange cir-

Adapted from the article, "Maximum Transmission Distance for RS-232 Computer Cables," in the Belden Innovators booklet, issue 3, 1987.

cuit. This capacitance value includes the part that is contributed by the cable.

The study described here was performed to determine the maximum acceptable length based on practical experiments. Many of the details of the study are omitted here because of space limitations.

How the study was done

A variety of different cables was tested under several operating conditions. The first test procedure consisted of transmitting data over a long length of cable using only a single channel. The length of the cable was then decreased until the data transmission became free of errors.

A second test was used to test the effect of cable length on crosstalk-related problems. To measure this effect, an increasing crosstalk voltage was applied to various lengths of cable until transmission errors were detected.

Different testing conditions were necessary because the maximum acceptable length depends on many factors, the first of which is how much of

the cable's capacity is being used. Minimum utilization occurs when only one channel is in operation, running at half duplex. This condition results in the longest permissible cable length.

Maximum utilization occurs when all channels are running at full duplex. This situation results in the shortest permissible cable length because crosstalk interferes with the desired signal.

By considering just these two test conditions, the study uses the maximum-utilization situation as a reliable, worst-case analysis for every partial utilization.

Other factors also have an impact on length. Cables operated in areas with high electromagnetic interference (EMI), for example, must be shorter. As a cable's length is increased, the probability that it will encounter noise also is increased. These facts tend to imply that the use of shielded cable is preferred in most cases and that cable capacitance is not the only factor to consider.

This study was performed under noise-free conditions. Although these conditions might appear to be unrealis-

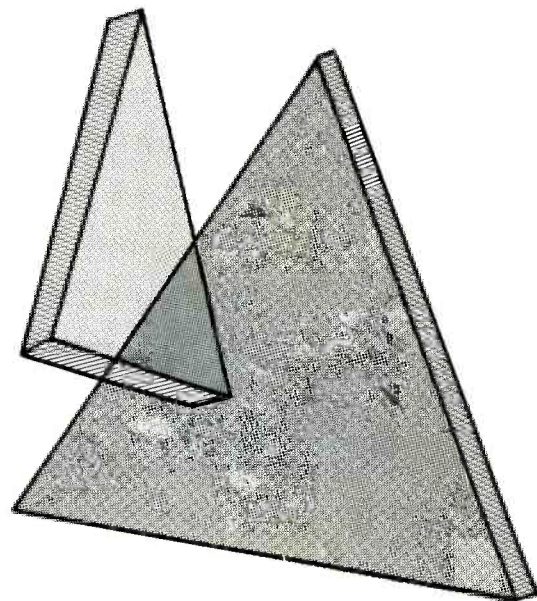

tic, properly shielded cables do minimize many noise problems. Consequently, this study tested only shielded cables. The use of shielded cables in RS-232 applications is recommended for this reason.

These tests used DTE (data terminal equipment) and DCE (data communications equipment) that were built using widely available components. The system is diagrammed in Figure 1.

The purpose of the study was to find, for specific cable types, the answers to the following questions:

- What is the maximum allowable cable length when the cable is operated at minimum utilization?
- What is the maximum allowable cable length when crosstalk voltage is present?
- What is the maximum allowable cable length when the cable is operated at maximum utilization?

Minimum utilization applications

The mechanism that limits the maximum transmission distance is jitter—a distortion of the original signal that causes errors on the receiving end. Jit-

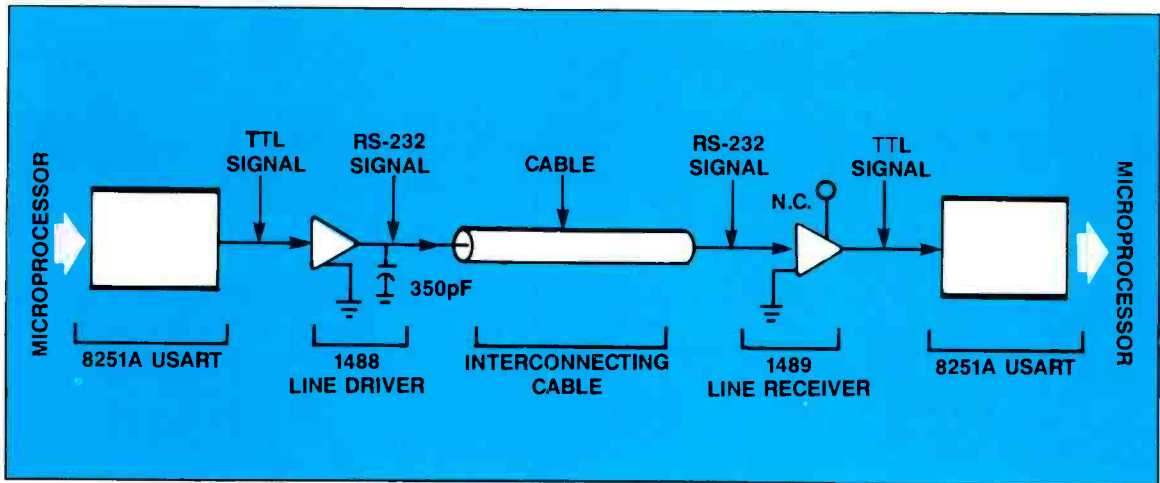

Figure 1. The test equipment setup.

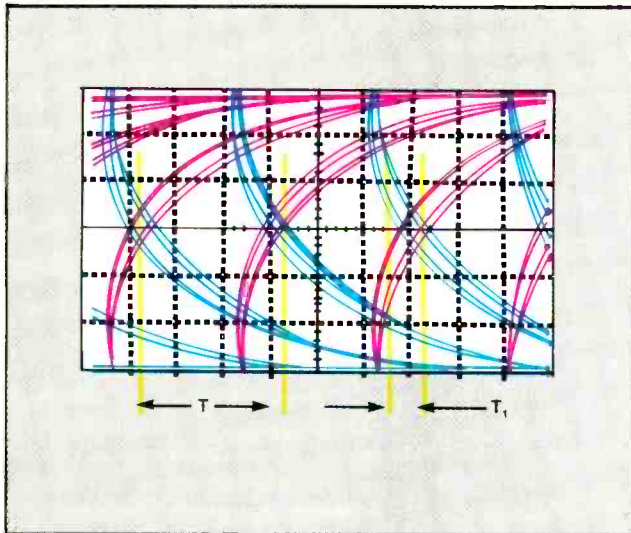

FIGURE 2

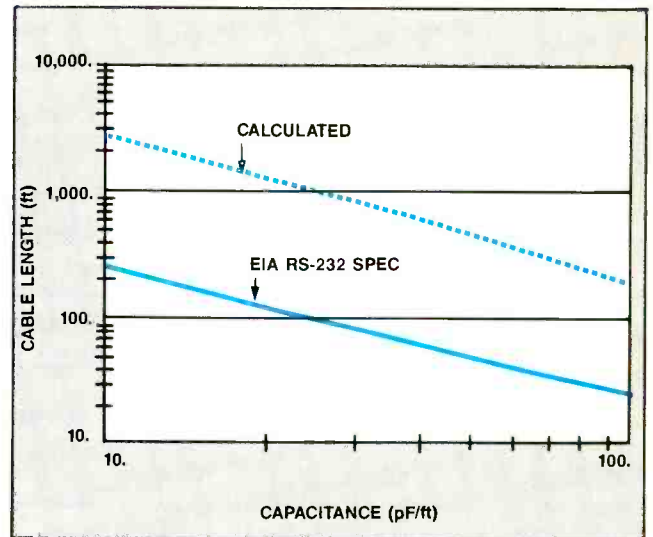

FIGURE 3

Figure 2. An eye pattern oscilloscope trace. A random data signal is displayed. If there were no jitter, the rise and fall of the signal would be sharp and not curved. As the jitter increases, the "eye" closes and the small diamond shape in the waveform grows in size. When this happens, the receiver has a harder and harder time distinguishing between a 1 and a 0.

Figure 3. Cable length vs. capacitance at a rate of 19.2 kilobaud. The capacitance is varied to calculate the maximum cable length. These results, calculated on the basis of experiments, are plotted in the upper line of the figure. The lower line shows the maximum recommended cable length according to the EIA RS-232-C specification.

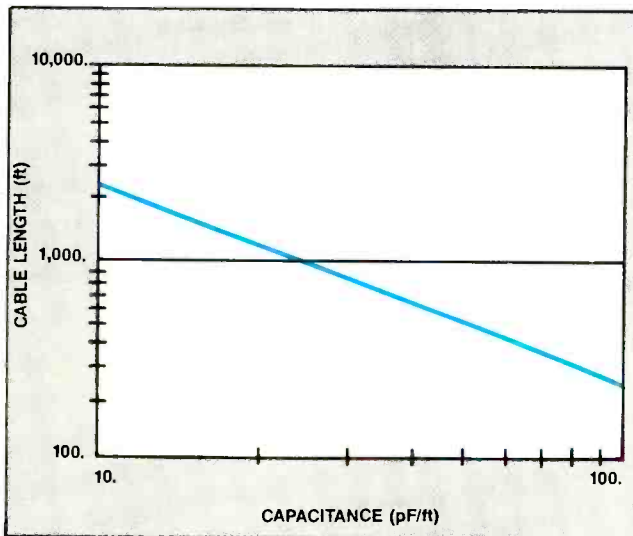
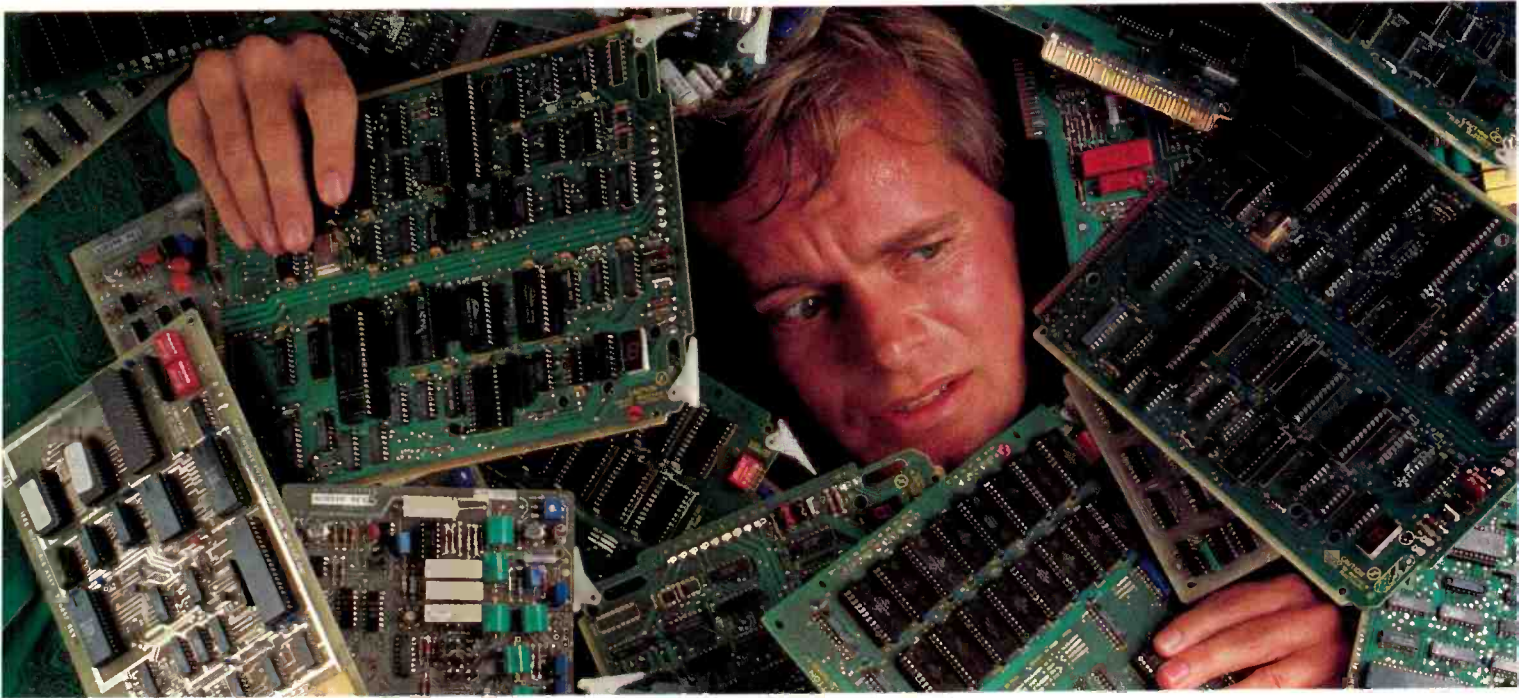

FIGURE 4

Figure 4. The recommended lengths with a 19.2 kilobaud baud rate (which will give a dependable worst-case limit for all applications) and a 20% safety factor.



PHILIPS



How to rescue yourself from a landslide of microprocessor board failures.

Complementing traditional troubleshooting tools, the Fluke 9010A can help decrease your board repair times by 55-80%.

You've got your oscilloscopes, your logic analyzers and your signature analyzers. But Fluke offers a better way to troubleshoot: the tool you'll reach for most. It's the 9010A Troubleshooter, a versatile board tester that's so easy to use, you can start testing the very first day.

The Fluke 9010A has a proven track record in saving repair time and substantially reducing board float. In fact, it has become the microprocessor repair tool of choice for over 2800 companies worldwide, including the leading computer and electronics manufacturers.

Test the easy way: from the microprocessor socket.

To begin board repair, remove the microprocessor from its socket and insert the interface pod connector in its place. Each

element of the microprocessor kernel (the bus, ROM, RAM and I/O) can be tested with a few simple commands.

Fluke's patented emulation technology offers real time testing and complete visibility throughout the circuit. This lets you test even the tough problem areas, including DMA, disk, video, communications and peripheral controllers. All diagnostic messages are presented in simple-to-understand English.

Comprehensive support from Fluke.

The 9010A supports over 50 microprocessors (including 180X, 6502, 680X, 680XX, 803X, 804X, 805X, 808X, 874X, 80X86, 9900, Z80, Z800X, 8751). And it is backed by Fluke's complete support network, which offers training courses nationwide on test strategy, basic operation and even μ P fundamentals.

In addition to the 9010A, the leader in emulative board test technology also offers the 9100A Digital Test System for a fully automated repair solution; plus the 90 Series, a compact inexpensive troubleshooting solution for 6809, Z80 and 8085 μ Ps.

To learn how you can escape the landslide, get your free video brochure "The 9010A μ P Board Repair Solution."

Call 1-800-44-FLUKE. EXT. 88 today.

John Fluke Mfg. Co., Inc. P.O. Box C9090,
M/S 250C, Everett, WA 98206
U.S.: 206-356-5400 CANADA: 416-890-7600
OTHER COUNTRIES: 206-356-5500

© Copyright 1988 John Fluke Mfg. Co., Inc.
All rights reserved. Ad No 0181-F9010.



The 9010A Microsystems Troubleshooter



Circle (7) on Reply Card

Table 1.
Crosstalk voltage at maximum utilization

Trade No.	Crosstalk voltage	Test length
9948	2.0V	500ft
9543	3.3V	500ft
9937	3.2V	1,100ft
9836, case 1	6.3V	823ft
9836, case 2	0.4V	1,030ft
8112, case 1	2.3V	1,410ft
8112, case 2	0.5V	1,041ft

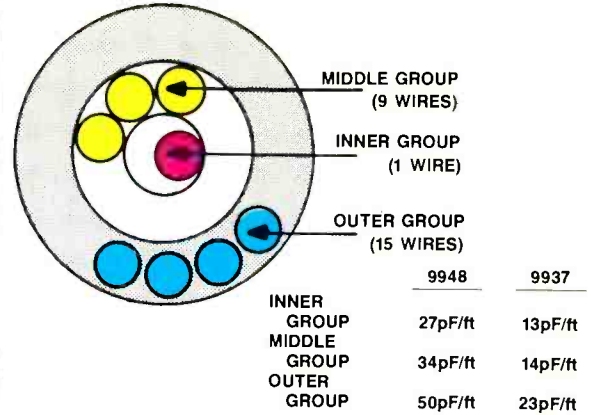

FIGURE 5

Figure 5. In order to apply the curve in Figure 4 to a specific cable type, you must determine the capacitance of the cable. There are several ways to make this measurement, depending on the cable construction. The figures to the left show the capacitance for two types of cable (9937 and 9948). Both are 25-conductor cables with foil/braid shields. The drawing shows how the 25 conductors are arranged in three groups inside the shield.

Figure 6. The effect of crosstalk voltage at 19.2 kilobaud for multi-conductor cable types.

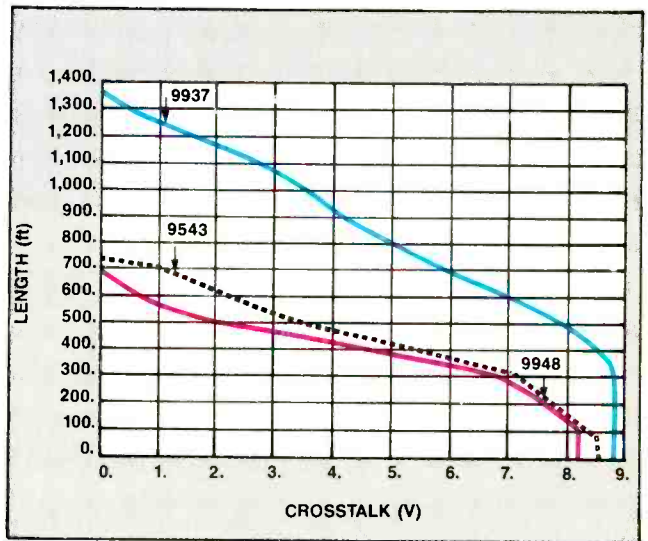

FIGURE 6

Figure 7. The effect of crosstalk voltage at 19.2 kilobaud for multi-pair cable types. Case 1 is with the unused wire in each pair left floating. In case 2, the unused wire in each pair is connected to ground.

Figure 8. The maximum transmission length of multiconductor and multipair cables at full utilization. (See the explanation in Figure 7 for cases 1 and 2.)

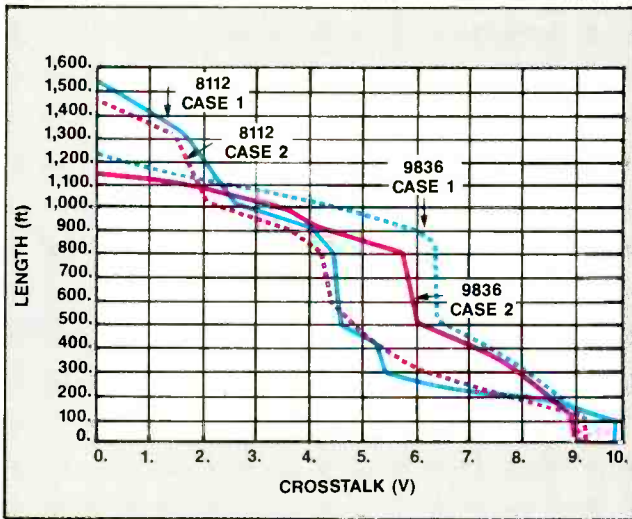

FIGURE 7

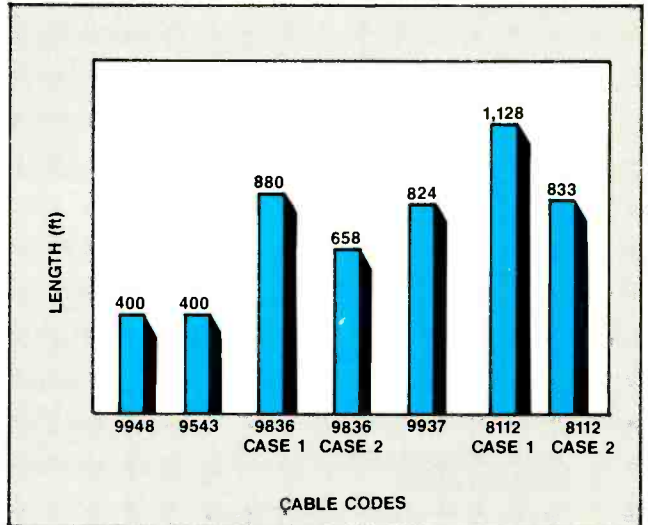

FIGURE 8

ter grows worse as a cable's length is increased.

Figure 2 shows a typical *eye pattern* on an oscilloscope screen. A random data signal is displayed. If there were no jitter, the rise and fall of the signal would be sharp and not curved. As the jitter increases, the "eye" closes and the small diamond shape in the waveform grows in size. When this happens, the receiver has a harder and harder time distinguishing between a 1 and a 0.

Mathematically, jitter is defined as the duration of the diamond (T_j) compared to the duration of a 1-bit cell (T):

$$\% \text{ jitter} = (T_j/T) \times 100.$$

When total system jitter (contributed by line driver, cable and line receiver combined) goes beyond 50%, the reconstructed data signal will experience transmission errors.

The electronics create 16% jitter. Thus, once the cable jitter reaches 34%, transmission errors will occur.

It was determined experimentally that the cable jitter equals 34% when the 0% to 50% rise time of the cable is equal to 0.52 divided by the baud rate:

The value 350 is the capacitance of the electronics themselves; this capacitance appears in parallel with the cable capacitance.

Equation 2 can be solved for L by substituting Equation 1 for the value RT. This gives:

Equation 3:

$$L = \{(0.52 \times 10^9)/0.9B\} - 350\text{pF/C}$$

where L = the maximum cable length (in feet),

B = data signal baud rate (in modulations per second),

C = cable capacitance (in pF/ft).

Figure 3 is a plot of Equation 3 in which the baud rate was fixed at 19.2 kilobaud and the capacitance varied so that the maximum cable length could be calculated. These results, calculated on the basis of experiments, are plotted in the upper line of the figure.

The lower line of Figure 3 shows the maximum recommended cable length according to the EIA RS-232-C specification. The data, calculated using Equation 3, suggest that the maximum transmission length is approx-

25-conductor cables with foil/braid shields. The drawing shows how the 25 conductors are arranged in three groups inside the shield.

The capacitance of a wire in each group with respect to the shield is presented in the table in Figure 5. Clearly, the outer-group conductors exhibit the greatest capacitance, and these worst-case capacitance figures will be used throughout the study.

The capacitance of the cable also is a function of the way the cable is connected in the application.

Applications with crosstalk

When more than one channel is used in a multi-conductor or multi-pair cable, the other channels will induce a voltage into the signal wire of concern. This voltage is known as *crosstalk*. When crosstalk is present, the maximum allowed transmission length decreases.

We won't go into detail about crosstalk here, but the effects of crosstalk on cable length for multi-conductor and multi-pair cables are shown in Figures 6 and 7, respectively.

Maximum utilization applications

Maximum utilization occurs when all the available channels within a cable are in use at the same time. This maximum-utilization condition generates an aggregate crosstalk voltage that is a constant value for any one specific cable hooked up in a specific configuration. This characteristic full-utilization crosstalk voltage was measured, and the results are listed in Table 1.

These test lengths cannot be considered the maximum *recommended* lengths because they are the threshold lengths at which errors just start to occur. When these lengths are reduced by the 20% safety factor, however, transmission accuracy is reliable. The resulting recommended maximum lengths are presented in Figure 8.

Even when worst-case conditions and 20% safety factors are included, you can often use cable lengths that are much longer than those suggested by the EIA standard. Cable length is dependent on the cable capacitance and crosstalk, and on the driver and receiver electronics. Cable lengths will be decreased if the system is subjected to external noise or ground loops. Because of the negative impact of external noise, shielded cable is recommended in most RS-232 applications.

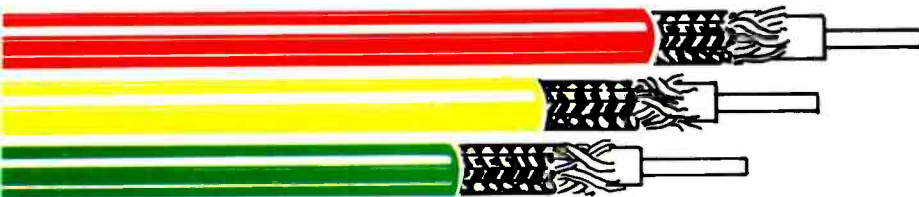

Equation 1:

$$RT = 0.52/B$$

where RT = 0% to 50% rise time (in seconds),

B = baud rate (in modulations per second).

Starting with Equation 1, you can calculate the maximum allowable cable length as a function of the baud rate and cable capacitance. Note that the cable's 0% to 50% rise time also has been determined experimentally to be

Equation 2:

$$RT = 0.9(L \times C + 350\text{pF})$$

where RT = 0% to 50% rise time (in nanoseconds),

L = cable length (in feet),

C = cable capacitance (in pF/ft).

imately ten times the EIA recommendation when the cable is used at minimum utilization (one channel, half duplex).

Even though lower baud rates might allow longer cables, this study will adhere to the lengths for 19.2 kilobaud for all baud rates. This figure will give a dependable worst-case limit for all applications. To further ensure a safe limit on maximum length, reduce the lengths of Figure 3 by 20%. The recommended lengths, including the safety factor, are presented in Figure 4.

In order to apply the curve in Figure 4 to a specific cable type, you must determine the capacitance of the cable. There are several ways to make this measurement, depending on the cable construction. Figure 5 presents information concerning two Belden cables: trade numbers 9937 and 9948. Both are

Test your electronics knowledge

By Sam Wilson, CET

ACROSS

1. Devices that are inserted between other devices for the purpose of isolation.
10. One method of displaying two traces simultaneously on a dual-trace scope is CHOP. The other is _____.
11. A method of interconnecting computers.
12. Enter computer memory.
16. You may think this canal has nothing to do with electronics, but it does have a current flow.
17. A type of motor with a shaft rotation equal to a specific number of degrees for each input pulse.
21. Get into resonance with.
23. When you see this word it means to divide.
24. Primary colors in an NTSC system.
26. Material used in solder.
27. An integrated circuit logic system in which the gates are chosen by equipment that is similar to a ROM burner.
29. An antenna that radiates equally well in all directions is an example of this type of radiator.
33. Program for a computer.

DOWN

1. An eraser for an audiotape. It erases a complete tape recording in a single effort.
3. Part of a heat sink.
5. Each.
6. Time constant circuit.
7. Putting into memory.
8. Number of decimal digits.

13. A component's lead (especially an IC).
14. Short form for electroencephalogram. A graph of brain waves.
16. Electric potential—not a common abbreviation.
17. A generator, used in pulse-code modulation, produces an output voltage in the form of _____.
18. Fast loaders of computer programs.
19. A space used in electronographic printing.
20. The same as 23 across.
22. The circumference of a circle

- equals $\pi \times$ _____.
25. A startup operation for computers.
27. Interface between the 6800 microprocessor and the outside world.
28. All of the components in a series-resonant circuit.
29. Interface between the computer and the outside world.
30. Type of transistor case.
31. Frequency used in AM broadcast.
32. Very popular word processor: C__RITE.

Answers are on page 41.

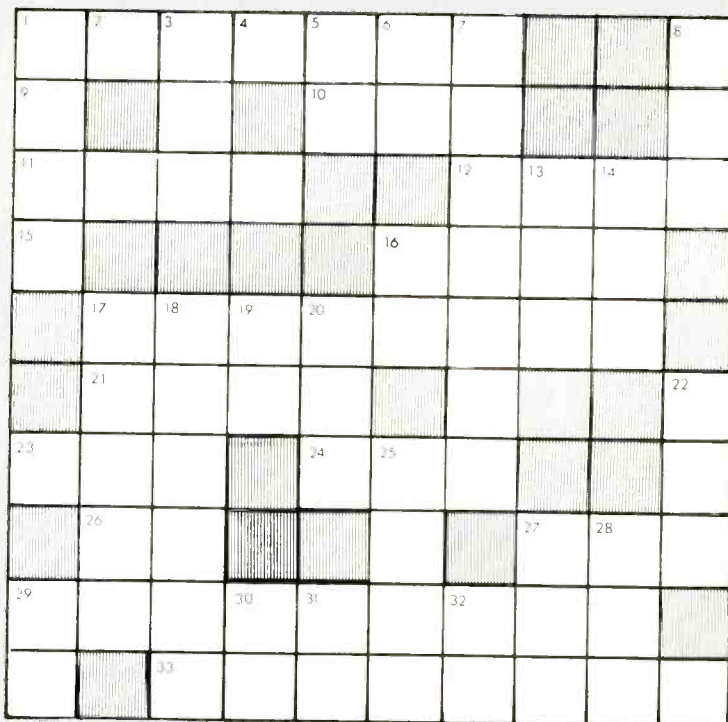

Wilson is the electronics theory consultant for ES&T.

Feedback

An Audio Corner glitch

If, for a moment, Sam Wilson could regress from his approach without mathematics, let's ask him to grade our work. Re: "More About Decibels," under the "A matter of relativity" subhead (see Audio Corner in the September issue), given S_2 twice that of S_1 , here's my mathematical fiction:

$$\begin{aligned} \text{dB} &= 10 \log S_1/S_2 \\ &= 10 \log 0.5 \\ &= 10(0.69897-10) \\ &= 10(-0.30103) \\ &= -3 \end{aligned}$$

Indeed, it is a matter of relativity. Your fiction shows gain; mine shows loss. Thanks for listening.

George T. Fogelman
El Paso, TX

Thank you for your letter, and for reading the Audio Corner department so closely. You are correct. What I should have said, of course, is that the dB gain of S_2 with respect to S_1 is $10 \log S_2/S_1 = 3$, which is the same as your result expressed another way.

Conrad Persson
Editor

Another Audio Corner comment

After reading Audio Corner in the June 1988 issue, I decided to try to answer your last paragraph by letting you in on what I am doing with my PC. I have been saving servicing magazines since 1969. I have a program called PFS FILE. I made a format to recall Symcures on a particular TV whenever I needed help in finding a quick solution to a particular problem. Now, for example, I have a TV that shows a dark area down the left side of the screen and, on adjusting the brightness and contrast, the picture doesn't change. PFS will find anything as long as you have a part of it in the search mode. In other words, under "symptom," if I couldn't remember how it was originally entered, I could enter it as .dark left side. and hit F10. It would hunt any symptom that has "dark left side." The more info you give the program, the faster it finds.

There may be a faster program but PFS hunts so many different ways that I don't think I would ever change over.

Richard H. Burroughs
San Antonio, TX

ES&T

Now PTS delivers tuners and modules

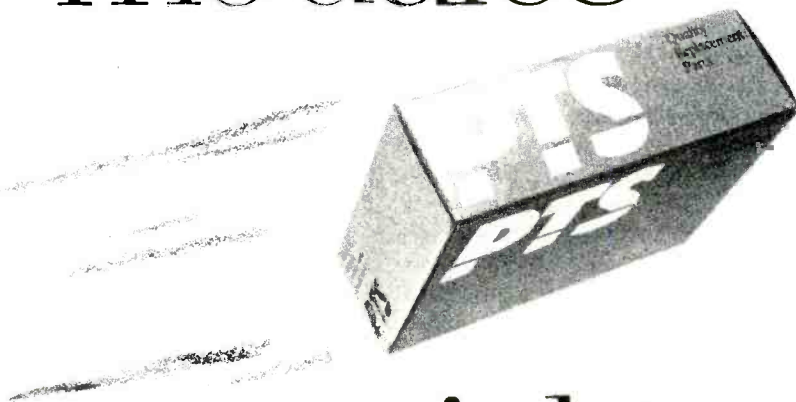

overnight.

Order all manufacturers' brands quality replacement parts direct from PTS with one toll free call. PTS—The nation's #1 replacement part company. Call toll free:

Introducing **PTS** **8/0/0**
Express
1-800-333-PTS1

Nationwide Servicenters and Distributors



Circle (9) on Reply Card

Power conditioning: Protecting your electronics investment

This article is based on two papers written by Charles F. Kerchner, Jr., P.E. Mr. Kerchner is President of Kalglo Electronics, Bethlehem, PA.

It can be an interesting tradeoff—Do you invest the money in protecting your computer against surges and blackouts, or do you take your chances during the next thunderstorm? A major factor in that decision might be the low cost of providing protection from power line perturbations compared to what it would cost to repair or replace damaged computer equipment. And with the increasing number of computers in homes and small businesses, more and more people are providing their computers with power-line protection and even uninterruptible power systems (UPS).

This article addresses two aspects of power-line protection: the possibility that a miswired receptacle might render a power-line protection device useless, and the fact that an UPS that delivers a square-wave output may be as effective as—and less expensive than—one that delivers a sine wave.

Making sure the receptacle is properly wired

House 120V wiring systems consist of three wires: a “hot” wire, covered with black insulation, with potential at 120V with respect to ground; a grounded neutral wire, covered with white insulation, that is at ground potential; and an uninsulated or green insulated equipment ground. In a correctly wired receptacle, the hot wire is connected to the narrow slot, the neutral wire is connected to the wider slot, and the ground wire is connected to the U-shaped grounding slot.

Unfortunately, although there is only one correct way to connect a receptacle,

there are several ways to miswire one. Some of these misconnections will result in short-circuits that will trip a circuit breaker or blow a fuse; others will not allow a connected appliance or other device to operate at all. These are self-diagnosing problems, so we won't discuss them here.

Three other cases of miswiring will allow a connected appliance to operate but may cause personal or equipment safety problems and defeat internal ground planes and RFI/EMI shields. They also may render power-line protection devices inoperative. These three cases are:

- Hot and neutral reversed.
- Neutral and ground reversed.
- Open ground connection.

It doesn't happen often that neutral and ground are reversed because the ground wire looks so unlike the other wires. But the other two conditions occur more often than they should, and it's a problem worth discussing. In all three of these cases, the computer or other electronics device will probably continue to work. However, the device may exhibit intermittent, unexplained glitches. The user then installs a surge protector and/or power-line noise filter, but the problem persists.

The problem doesn't go away because the electrical energy is not being correctly applied to the computer, so its ground planes are not operating properly. There may also be high-frequency sneak paths into the logic, which the equipment designer never considered—he assumed that the outlet would be wired correctly. The protector manufacturer also assumes the outlet is wired correctly, so a surge protector is of no help. In the case of the open ground connection, the operator is exposed to

potential shock if a part malfunctions or the equipment's insulation exposes energized conductors.

Miswired outlets also can damage other energy-generating devices such as emergency power systems and UPS. Most UPS switch only the hot wire relative to the common neutral; if the hot wire is not hot but is instead the neutral, the UPS and the electrical system may both be energized simultaneously and cross-connected such that voltages higher than 120V exist, causing damage to the UPS or other equipment.

According to one company, miswired outlets are the cause of problems in 0.5% to 1% of all outlets they encounter. Fortunately, this is a small percentage, but if you consider how many outlets are installed, 1% is still a large number.

If you run across a strange problem in an electronic product, you might start your diagnosis by checking to make sure the outlet it gets its power from is properly connected. The simplest way is to buy an outlet wiring-integrity checker.

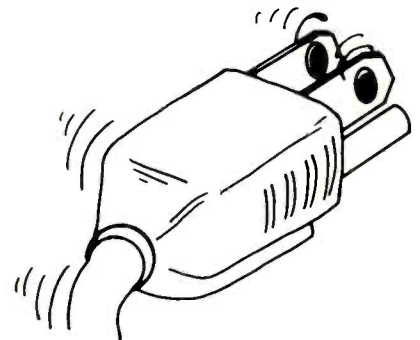

When you plug in this device, one or more of its three lights light up to tell you whether the outlet is properly wired and what any problems are. Many surge/noise protectors have built-in wiring integrity checkers that will let you know as soon as you plug it in if there is a problem with the wiring.

If you don't wish to buy one of these devices, you can make the same check with a multimeter. Simply set it to ac and probe between all the slots in the receptacle two at a time. If the receptacle is properly wired, you should measure 120V from hot to ground, 120V from hot to neutral, and 0V from neutral to ground. Any other readings mean something is wrong, and you should get an electrician to straighten it out.

Power-line protectors will help keep spikes and surges from damaging elec-

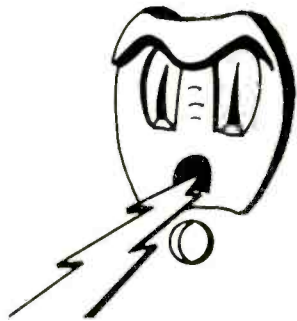

tronic equipment, but only if the receptacle it's plugged into is properly connected.

Round tops vs. square tops

Of course, before you need to worry about connecting your equipment and UPS systems, you have to choose which protection you need. Does the output of

The Philips ECG DT-200 Temperature Adapter turns your digital multimeter into a thermometer!

Our DT-200 Temperature Adapter can turn your digital multimeter into a direct-reading thermometer for minimal additional cost. Take a look:

- uses K-type thermocouple (included)
- temperature to voltage converter with a linear 1.0mV DC/degree output with $\geq 10M\Omega$ input impedance meters
- 6 output jacks assure perfect fit with almost any digital multimeter
- measurement range of -50° to -2372°F and -50° to 1300°C



Contact one of our more than 900 distributors, or call 1-800-225-8326 for the name of the distributor nearest you. It just might be the smartest call you make all week.

The Smart Choice.

Philips ECG

A North American Philips Company

Circle (10) on Reply Card

The ECG pocket-sized DM-51 Multimeter is packed full of features!

The ECG[®] DM-51 Multimeter is part of our new line of compact multimeters that combine small size with big features. The DM-51 can easily be carried in a repair kit, bag, or even your shirt pocket!

- measures up to 200 M Ω
- up to 10 amps DC
- test batteries—9V, 1.5V
- transistor hFE test
- diode test
- continuity beeper



Contact one of our more than 900 distributors, or call 1-800-225-8326 for the name of the distributor nearest you. It just might be the smartest call you make all week.

The Smart Choice.

Philips ECG

A North American Philips Company

ECG Replacement parts keep VCR's in top shape!

To replace VCR mechanical parts look no further than Philips ECG.[®] Our new line can replace mechanical parts for most major brands of VCR's and our catalog contains the most accurate cross-references by part number and model number. Other features:

- line includes 13 pinch rollers, 33 idler wheels and assemblies, 4 idler replacement tires and 46 belt kits
- individual belts available

Nobody makes it easier to get VCR replacement mechanical parts than Philips ECG! Contact one of our more than 900 distributors, or call 1-800-225-8326 for the name of the distributor nearest you. It just might be the smartest call you make all week.



The Smart Choice.

Philips ECG

A North American Philips Company

Circle (25) on Reply Card

an UPS have to be a sine wave? The answer in most cases in microcomputer applications is no. Sine-wave output UPS systems are really only necessary for continuous on-line UPS systems and certain directly supplied ac motor-driven disk drives. Because most if not all microcomputer systems are operating the CPU and the disk drives off an internal dc power supply, sine waves are not necessary for an emergency backup UPS.

There are basically three waveform types used with UPS for microcomputer applications: square wave, sine wave and pulse-width modulated (PWM) stepped rectangular wave. The frequency of all three types of waveforms must be tightly controlled. Also, some form of maximum voltage-governor limiting device should be used to limit the maximum output average or rms voltage to safe levels. Limiting the output prevents overheating of the computer power supply, especially continuous on-line units. Although this feature is not as critical for emergency standby units, it is a very desirable feature.

The least expensive waveform to provide is the square wave. Next in price range comes the PWM stepped wave, then the higher priced sine-wave units. Sine-wave units use the same principles as square- and stepped-waveform units, but they add an additional filtering device or transformer on the output to convert the waveform to an approximate sine wave.

Some people disparage all types of waveforms other than the sine wave. The type of waveform needed, however, really depends on factors such as what type of load it will be used with, whether or not it is a continuous on-line unit or an emergency standby unit, and how much the purchaser is willing to pay to protect a computer system from crashing.

The backup requirements for modern microcomputer power supplies, which in turn supply dc voltage to power the CPU and the floppy or hard disk drives, are a lot different from the backup requirements for a mainframe computer or a disk drive driven by a synchronous ac motor. Most if not all microcomputer disk drive motors are dc driven and use phase locked-loop (PLL) technology to maintain frequency and speed control, so they don't need sine waves. Also, the waveform shape and tolerance requirements are a lot different for running a system off the UPS continuously on-line for 8 to 24 hours a day as opposed to

two to ten minutes in an emergency situation to prevent a system crash due to momentary or temporary power failure.

The power generated and supplied by the local utility is a sine wave. This is because it is generated by rotating ac machinery, and sine waves are a natural product of rotating machinery. Just because the sine wave is the waveform provided by the utility does not make it the only or necessarily the best waveform to use for computer backup. There are other factors to consider as outlined previously. In fact, for computer power supplies, most engineers would tell you it would be better if smooth dc came out of the wall outlet instead of ac sine waves. Sine waves are great for power generation and transmission over great distances, but dc runs modern microcomputers. Interestingly enough, square

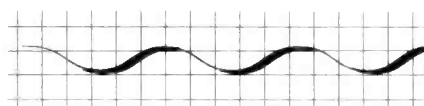

Which waveform is better for a given application depends on what it will be used for and whether it is for continuous or standby use.

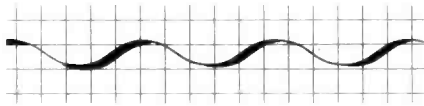

waves and PWM stepped rectangular waveforms make better sources for rectification into smoother, more ripple-free dc voltages than do sine waves.

The reason is that these "flat-topped" waveforms have a higher average output voltage value, and the output voltage is at peak value longer than for "round-topped" sine waves. All engineers know that the charging of a dc power supply occurs at the peak of the waveform. Because flat-topped waveforms are at the peak longer, they keep the dc-supply input fully charged longer; thus, the dc output is smoother. This fact can be easily demonstrated by attaching an oscilloscope on the output of a dc power supply and observing the ripple with a sine-wave input and then a square-wave or stepped-waveform input, all of equal rms value. The dc is smoother with the

flat-topped waveforms than with round-topped sine waves.

Other people who disparage flat-topped waveforms say they run off-frequency and cause overheating. As mentioned earlier, either type of waveform can be off-frequency and thus cause overheating. Frequency control is very important and is a separate, unrelated parameter. It has nothing to do with the waveform shape. All good units have tight frequency control (within 0.5%) regardless of waveform.

Another criticism is lack of control of the rms output voltage. This is an important parameter. Low-cost square-wave and sine-wave units both have unregulated outputs. They run wide open with the output value dependent on the level of the inverter battery. This problem is solved with pulse-width modulation in flat-topped waveforms and voltage-regulating transformers in sine-wave units.

Another argument concerns harmonics and audible noise. It is true that flat-topped waveforms generate more harmonics and audible noise because of the fast rise time of the waveforms. However, good units use high-frequency EMI filters on the output to remove any potential interference. The higher audible sound may be objectionable with continuous on-line units running all day long, but it has no effect in emergency applications using a standby UPS on modern microcomputer systems. The audible sound is most likely coming from the computer's internal cooling fan, not the computer's dc power supply. This square-wave supply power also will not hurt the fan for short-term emergency use.

An advantage of PWM and stepped waveforms often overlooked is that flat-topped waveform units can be faster because it takes longer to create a stable sine wave than to create a flat-topped waveform. And transfer time is a critical parameter for standby units, especially when they are used with modern microcomputers, which, unfortunately, do not have much reserve capacity or coasting time built into them. Thus the transfer must be done as quickly as possible—another plus for flat-topped units. Of course, if you have an on-line unit, transfer time is irrelevant.

In summary, which waveform is better for a given application depends on what it will be used for and whether it is for continuous or standby use.

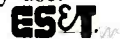

ES&T STATEMENT OF OWNERSHIP

Statement of Ownership, Management and Circulation (Act of August 12, 1970; Section 3685, Title 39, United States Code).

1. Title of publication: Electronic Servicing & Technology
 - 1A. 462-050
2. Date of filing: Sept. 30, 1988
3. Frequency of issue: Monthly
 - 3A. Number of issues published annually: 12
 - 3B. Annual subscription price: \$19.49 U.S.
4. Location of known office of publication (Street, city, county, state, zip code): 9221 Quivira Rd., Overland Park, Johnson County, Kansas 66215.
5. Location of the headquarters or general business offices of the publishers (not printers): 9221 Quivira Rd., Overland Park, Johnson County, Kansas 66215.
6. Names and complete addresses of publisher, editor, and managing editor. Publisher (Name and Complete Mailing Address): Eric Jacobson, 9221 Quivira Rd., Overland Park, Kansas 66215. Editor (Name and Complete Mailing Address): Nils Conrad Persson, 9221 Quivira Rd., Overland Park, Kansas 66215. Managing Editor (Name and Complete Mailing Address): Tom Cook, 9221 Quivira Road, Overland Park, KS 66215.
7. Owner (If owned by a corporation, its name and address must be stated and also immediately thereunder the names and addresses of stockholders owning or holding 1 percent or more of total amount of stock. If not owned by a corporation, the names and addresses of the individual owners must be given. If owned by a partnership or other unincorporated firm, its name and address, as well as that of each individual must be given. If the publication is published by a nonprofit organization, its name and address must be stated.) Intertec Publishing Corp., a Macmillan Inc. company, 9221 Quivira Rd., Overland Park, KS 66215.
8. Known bondholders, mortgagees, and other security holders owning or holding 1 percent or more of total amount of bonds, mortgages or other securities (If there are none, so state): Macmillan, Inc., 866 Third Ave., New York, NY 10022.
9. Paragraphs 7 and 8 include, in cases where the stockholder or security holder appears upon the books of the company as trustee or in any other fiduciary relation, the name of the person or corporation for whom such trustee is acting, also the statements in the two paragraphs show the affiant's full knowledge and belief as to the circumstances and conditions under which stockholders and security holders who do not appear upon the books of the company as trustees, hold stock and securities in a capacity other than that of a bona fide owner. Names and addresses of individuals who are stockholders of a corporation which itself is a stockholder or holder of bonds, mortgages or other securities of paragraphs 7 and 8 when the interests of such individuals are equivalent to 1 percent or more of the total amount of the stock or securities of the publishing corporation.
10. This item must be completed for all publications except those that do not carry advertising other than the publisher's own and are named in sections 132.231, 132.232 and 132.233, postal manual (Sections 4355a, 4354b, and 4356 of Title 39, United States Code).

	Average No. Copies Each Issue During Preceding 12 Months	Single Issue Nearest To Filing Date
A. Total No. Copies Printed (Net Press Run)	45,217	46,300
B. Paid and/or Requested Circulation		
1. Sales through dealers and carriers, street vendors and counter sales	--	--
2. Mail subscriptions	42,605	44,374
C. Total Paid Circulation	42,605	44,374
D. Free Distribution (including samples) by mail, carrier delivery or other means	924	823
E. Total Distribution (Sum of C and D)	43,529	45,197
F. Office use, left-over, unaccounted spoiled after printing	1,688	1,103
G. Total (Sum of E and F should equal net press run shown in A)	45,217	46,300

I certify that the statements made by me above are correct. (Signature of editor, publisher, business manager, or owner.)
 ERIC JACOBSON
 Publisher

CHEMTRONICS ANNOUNCES

Ozone Safe

Ultrajet[®]

fact: E-Series™ Ultrajet is manufactured with an EPA-designated substitute for the ozone depleting CFCs found in conventional gas dusters.

fact: Laboratory pure E-Series Ultrajet is ultra-filtered to < 0.2 microns, inert and nonflammable.

fact: Powerful non-abrasive 120 PSI jet removes dust and contaminants from computers, electronic devices, optical surfaces, photographic and laboratory equipment.

fact: Economical new ozone safe E-Series Ultrajet is available now only from Chemtronics.

For more information, contact Chemtronics at 800-645-5244 (in NY 516-582-3322).



681 Old Willets Path, Hauppauge, NY 11788
 Circle (11) on Reply Card

A homemade high-vacuum desoldering system

By William L. Call

One of the biggest headaches in servicing electronic equipment is desoldering the parts, particularly when you're servicing newer equipment that uses ICs with many pins. When these ICs are not in sockets, removing them quickly and with no damage to the board (or to the part, in case it turns out to be OK) is very important. Several desoldering methods are currently popular:

- *Desoldering braid or wick.* With this method, the technician places a special desoldering braid over the joint to be desoldered and then heats the back side of the braid with the iron. The braid is treated with rosin, which enables it to soak up the solder. The melted solder

is drawn by capillary action into the braid. After each joint is melted, the braid is clipped off to expose fresh material for the next joint. The braid method usually does a thorough job, but it is slow, it covers the board with rosin residue, and it does only a marginal job on plated-through holes.

- *Desoldering pump or "solder-sucker."* This method uses either a rubber bulb or, preferably, a plunger-type pump. The joint to be desoldered is heated with a soldering iron until it is melted; the pump is then placed over the protruding lead and released, sucking the molten solder into the pump. This method is sometimes faster than braid, but it often does an incomplete desoldering job because the solder cools and solidifies rapidly when the iron is

removed. The pumps have to be cleaned out frequently, and the tips must be replaced.

- *Desoldering iron with hollow tip and a rubber suction bulb.* This method usually works well, although squeezing and releasing the bulb can be tedious. Also, because the suction isn't very strong, it sometimes leaves behind solder.

- *Vacuum-powered hollow-tip iron.* This is the ultimate desoldering tool. Some type of vacuum pump is used to pull the solder into a reservoir for later removal. Operation is quick, clean and usually very complete. Vacuum-powered desolderers have been on the market for several years, but they usually cost \$400 to \$600. After using one, however, you'll find that the other methods seem tedious and terribly slow.

It's not that hard to build a vacuum desoldering system for yourself, and you can do it for a lot less than the commercial models cost. I've built several, and by shopping the surplus market or junkyards, I've built them for about \$50 to \$100. My units desolder better than any commercial unit I've used because they provide a stronger vacuum.

The basic setup is shown in Figure 1. Two versions I have built are shown in the photographs on pages 22 and 23. If you've seen commercial units, you will notice some differences right away—I use a vacuum storage tank and two solenoid valves. Commercial units just use a carbon-vane pump or a venturi system and compressed air, starting the vacuum flow from atmosphere for each connection to be desoldered.

The system described here pumps a deep vacuum into a tank, then releases the stored vacuum as needed through a valve. This method produces a deeper, more sudden vacuum that does a better

Call is assistant professor in the department of engineering technology at Murray State University.

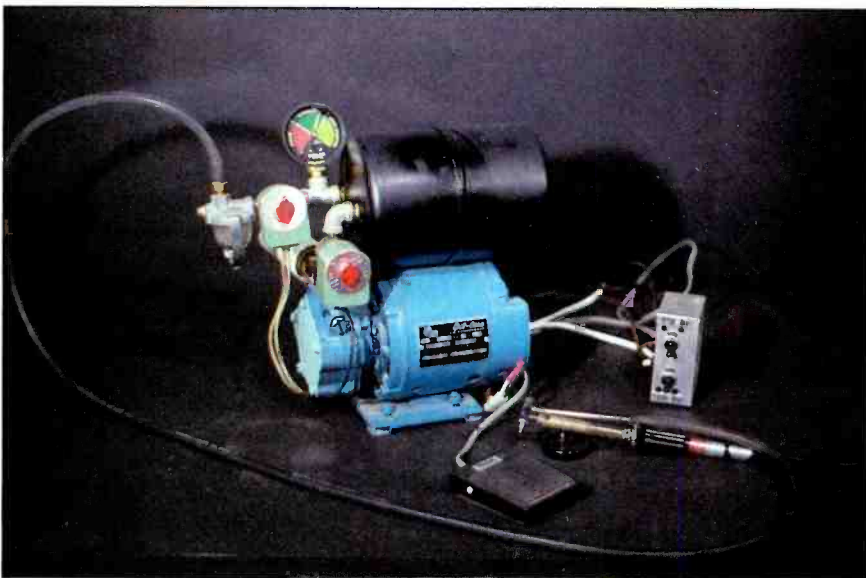

In the first system constructed, the pump is on the bottom. The tank is above, supported by the connecting pipe. This particular tank had two outlets, which were both used, so only one tee was required (visible under the gauge). The control box, on the right, is mounted to a leg of the workbench, while the pump unit sits on the floor under the bench. The footswitch and iron are visible in the foreground.

job of pulling solder through the connection holes and breaking up the "sludge" of liquid solder into small pellets as it enters the iron.

Of course, if you find a fast-responding vacuum pump and want to experiment, you could try your own system by eliminating the valves and tank, switching the pump on with the foot switch for each joint. This should be as good as the commercial units. I'll just describe the high-vacuum system that I've built, however.

Finding the parts

To build your own system, you first need a hollow-tip iron. The only easy source I've found is a rubber-bulb desoldering iron with the bulb removed and the delivery pipe hooked to the vacuum system. Connect the iron to the vacuum system through a length of automotive vacuum hose; the clear hose is nice because you can find solder plugs easier, but the black type holds up better with the heat. Quarter-inch black automotive vacuum hose makes a good slip-fit over the pipe end of an iron. Some irons also have a small barb that helps secure the hose. You may have to clamp the hose in place with a small cable tie.

Suitable vacuum pumps are available through a number of surplus-equipment companies. (See the "Sources" sidebar.) You don't need a lot of volume capacity, but try to find one that will pump down to about 20 to 24 inches ultimate vacuum. (Most commercial desoldering units only produce 15 to 20 inches.)

Incidentally, the measure of a vacuum's strength is usually given as the height of a column of liquid mercury that the suction of this vacuum could support. The highest obtainable vacuum is about 30 inches of mercury,

equivalent to -15PSI. This is the vacuum of outer space.

I found a Bell & Gossett compressor/vacuum pump for \$39.95 for my first unit, and it works well. For my second system, I had access to an orphaned high-capacity scientific pump, but it would be out of the question for most of us to purchase. Most pumps are pretty noisy, so I made a simple muffler for the first one by running the outlet pipe into a wad of sponge stuffed into a cardboard tube. Since then, I've found a surplus-market muffler that works better.

The solenoid valves are 2-port (one in and one out), normally closed. I

would suggest that it have a 1/8-inch orifice (the internal passage size) or larger. A 3-port valve could be used if you didn't connect the extra port. One valve is used to open the vacuum path to the iron in response to a tap on the foot switch; the other opens the path to the pump during pump-down of the tank and closes this path to prevent loss of vacuum at other times.

A coil voltage of 120Vac is probably the easiest to obtain and to work with, although lower-voltage solenoids fed through a transformer would be safer. I addressed the safety concern by using a 3-prong (grounded) plug and by maintaining a grounded path through all the



In the second system, the vacuum pump is not shown. The tank is an old 30-pound Freon bottle. The solenoid valves are supported by brackets bolted to the tank handles. A 4-way cross tee is used between the valves, with one outlet to the gauge, one to the tank and the others to the valves. A length of copper tubing with flare fittings connects the tank to the tee. A control panel is fabricated from a piece of aluminum and bolted to the handles. A lamp was installed on this panel to indicate when the iron was on. Electrical outlets were provided for the iron and for the vacuum pump. The iron and footswitch are visible in the foreground.

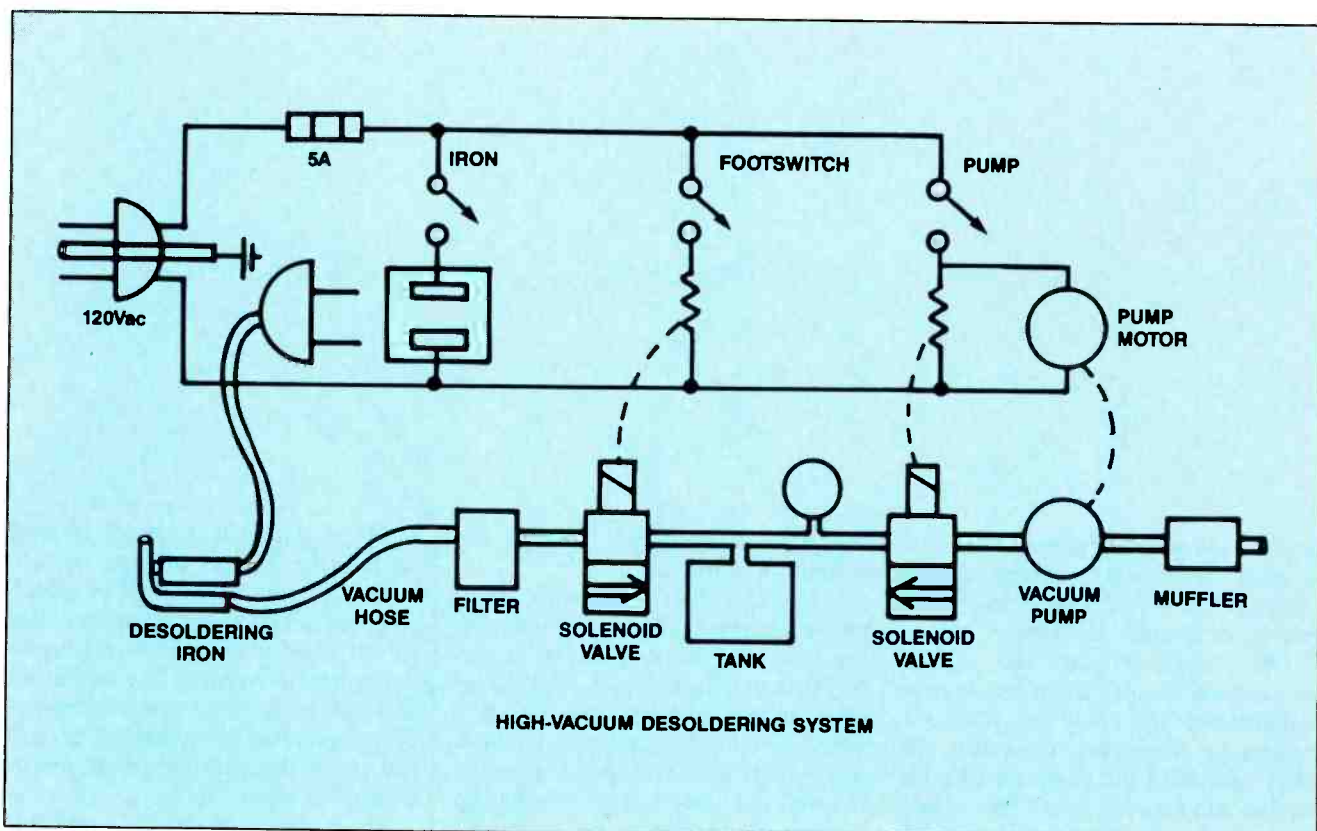

Figure 1. This basic system diagram shows the electrical systems (Figure 1A) and vacuum system (Figure 1B). The arrangement of vacuum piping connectors is not detailed—install as required.

metal parts. Thus, if a solenoid coil shorts to the frame, the fuse should blow. I paid \$6.95 each for my first pair of valves, but I found the second pair for \$1 each at a ham-radio flea market.

The vacuum storage tank should be large enough to allow desoldering of a number of leads without repumping, but it should be small enough to be manageable. The first system uses a half-gallon surplus tank—quite compact but a little shy in capacity. If I have no problems, I can desolder a 14-pin IC without turning the pump back on. This particular tank had two openings (see the picture on page 22), so I used both and saved buying a tee. As pictured, I mounted it above the pump, supported only by the connecting pipe. For the second system, I talked a local air-conditioner servicer out of an empty 30-pound Freon bottle. The capacity is fine and so is the price.

Making the connection

Perhaps a word is in order here for those readers not familiar with the fittings and connectors used in the vacuum portion of the system. The valves will probably use internal pipe threads, usually sized for 1/8-inch or 1/4-inch ID pipes. The valves and gauge are con-

nected by two *tee* fittings or one *4-way cross* fitting and some short threaded pipes, all using pipe threads of the chosen size. The pump and filter probably also will use pipe threads, and

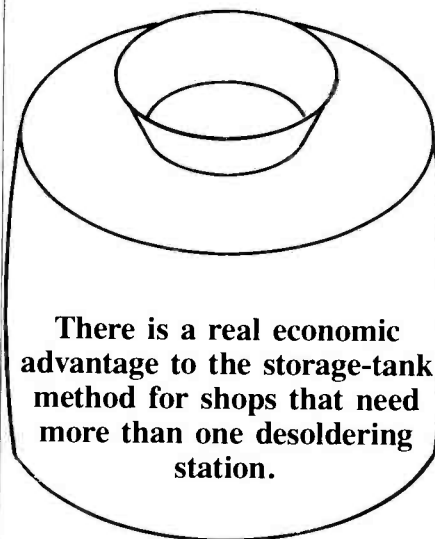

There is a real economic advantage to the storage-tank method for shops that need more than one desoldering station.

short pipes threaded on each end can connect them to a valve; 90° elbow or different-size adapters also may be required, or you can connect the pump with a hose.

To connect with a vacuum hose, a

hose barb connector is screwed into the pipe threads and the hose is then pushed onto the tapered barb. The Freon tank uses a *flare* fitting, which can be connected with a 1/4-inch ID flared copper tubing line to the tee or cross with a flare-to-pipe thread connector/adaptor at the tee. With adapters, the tank's flare fitting also could be converted to connect hose or pipe, then plumbed in.

There are several ways to connect the pipes, and it's probably best to obtain your pump, tank and valves before purchasing the adapters. In the first system, I used the two inlets available to eliminate a tee, and I supported the tank above the pump with the connecting pipe. The second system is much different—the tank is connected through a flared copper tubing line and the vacuum pump connected with hose. Except for the expensive pump, this system is more likely to be duplicated, so I've drawn an expanded plumbing hookup drawing (See Figure 2) to illustrate.

The problem is much like hooking all our signal generators and other test equipment up to equipment being repaired—a big box of cables and adapters is most helpful. Any good-sized plumbing or auto parts store should have the fittings and adapters you

need, and a knowledgeable clerk can take your components and cleverly connect them. The clerk should be able to flare copper line for you, too, if you don't have a flaring tool.

Putting it all together

Returning to the system components, the filter's purpose is to catch solder pellets as they whiz down the hose, keeping them from clogging the valve. I used a sediment-bowl lawn-mower gasoline filter that I bought at the local auto parts store. To reduce obstruction, I drilled out the passages to 3/16-inch. Better filters could probably be found for less work. Those designed for air compressors should work well, except those with semi-automatic liquid drains in the bottom, which won't seal with a vacuum.

Sometimes the filter is supplied with the pump—C&H Sales and Meshna show suitable-looking combinations in their catalogs. These filters could be removed from the pump and installed at the indicated place. It turns out that a lot of the solder remains in the iron, and the filter doesn't have to be cleaned often.

The vacuum gauge indicates when the vacuum is weak and the pump should

be turned on. A more advanced system would use a pressure switch to automatically start the pump. I used a cheap surplus auto vacuum gauge on the first system, but I found a better one that read 0 to 30 inches of vacuum directly for the second unit.

Finally, find a convenient spot for a control panel to switch the pump and iron on and off. For the first unit, I used a mini-box mounted to a leg of the workbench; for the second systems, I attached a metal panel to the handle frame

of the tank. Either approach is workable.

There is a real economic advantage to the storage-tank method for shops that need more than one desoldering station.

A single vacuum pump and tank can be connected to several desoldering stations, each with their individual iron, footswitch, filter and a single valve. I've built a system like this for a student lab at the university where I teach. A pressure switch instead of a manual switch to control the pump works bet-

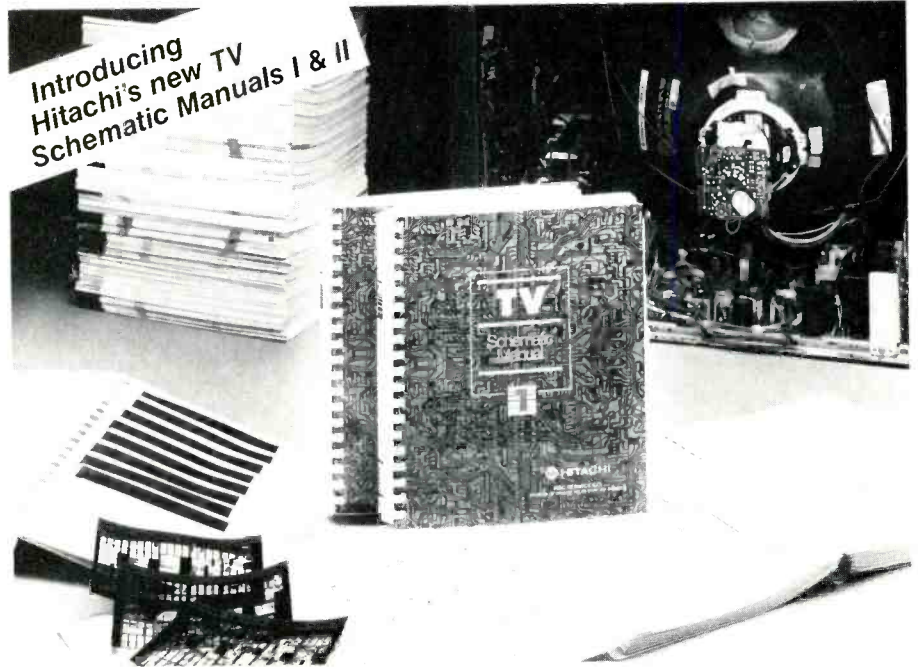

Sources of surplus vacuum parts

All Electronics
P.O. Box 567
Van Nuys, CA 91408
800-826-5432

C and H Sales
P.O. Box 5356
Pasadena, CA 91107
800-325-9465

Herbach & Rademan
401 E. Erie Ave.
Philadelphia, PA 19134
215-426-1708

Hosfelt Electronics
2700 Sunset Blvd.
Steubenville, OH 43952
800-524-6464

John J. Meshna Jr.
19 Allerton St.
Lynn, MA 01904
617-595-2275

All the technical data of 83 Hitachi TV Manuals—in just two volumes



Our new Hitachi TV Schematic Manuals give you the best of both worlds—

With the compact storage of 32X microfiche and full-view hard copies of the items you use the most. Organized by year and model number in both formats, these volumes give you everything you need—83 models from 1975–1981. They're neatly packaged, easy to use, and economically priced.

You'll get hard copies of:

- Schematic Diagrams • Block Diagrams
- Printed-Circuits Board Layouts • Part Lists • Mechanical Part Exploded Views

And get the works on microfiche:

- Service Manuals with Technical Data and Information • Troubleshooting Tips • Revised or Supplemental Manuals • Instruction

Manuals • Parts and Service Bulletins

Volume I covers: 54 models from 1975–1978

Volume II covers: 29 models from 1979–1981.

That's a lot of service data for a low **\$54.95** per volume! About what you would expect to pay for information on only two models. Or save even more by getting both volumes for just **\$104.00**. Take advantage of these savings now. It's a simple, cost-effective way to increase proficiency and increase profit. Also available are our VCR Volumes I, II and III.

Call toll-free 1-800-447-2882 for your nearest Authorized Hitachi Distributor

HSC Service Company

division of Hitachi Sales Corporation of America

Circle (8) on Reply Card

November 1988 *Electronic Servicing & Technology* 25

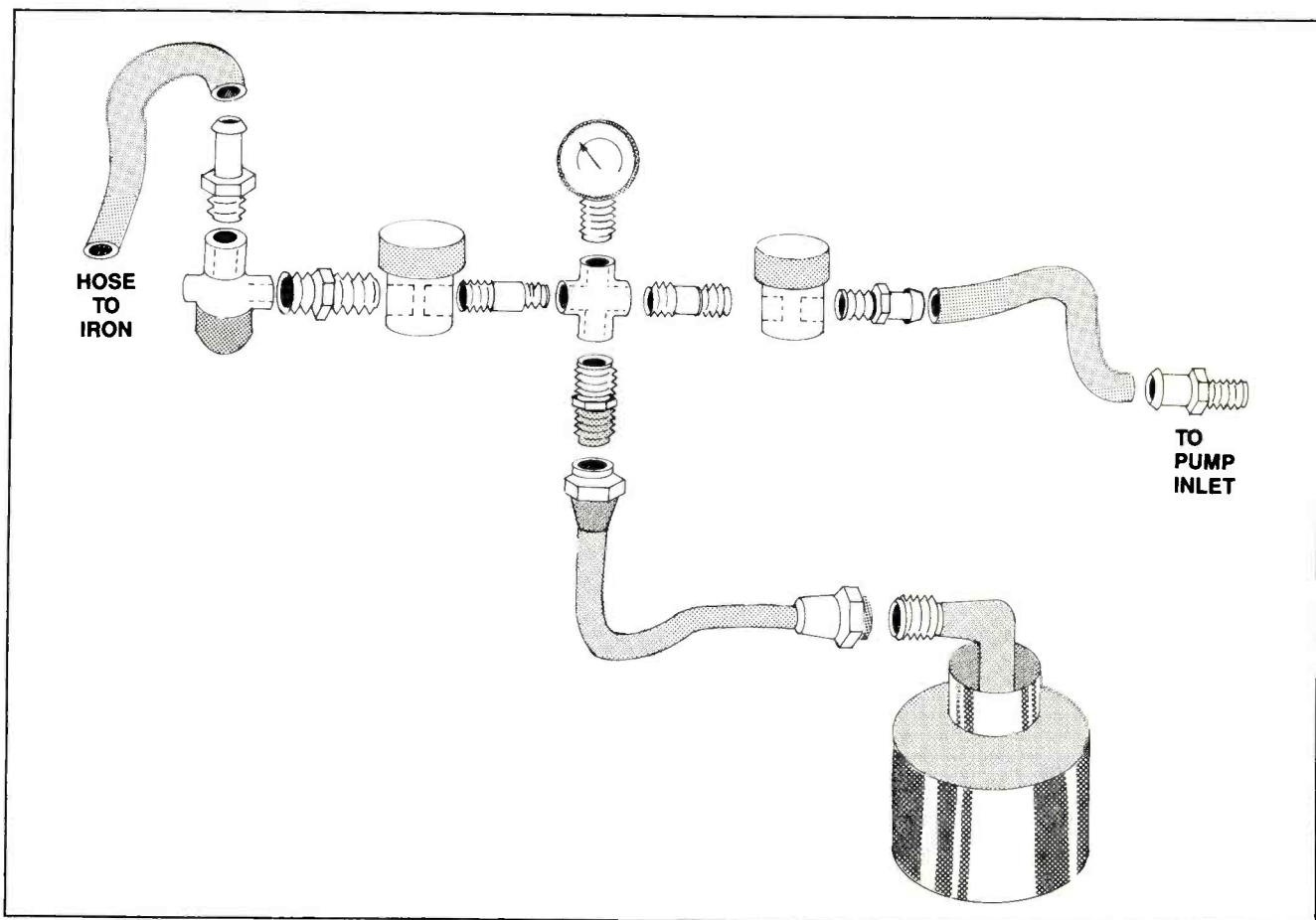

Figure 2. This expanded plumbing hookup drawing shows the connections used in the second desoldering system.

ter for this type of installation.

Using the system

To desolder a joint with this system, first warm up the iron and pump the tank vacuum down to ultimate, about 24 inches with a typical small pump. Place the tip of the iron over the lead to be desoldered. When the solder melts, tap the foot switch. Usually that's all there is to it.

Old, oxidized connections or very small plated-through holes, which don't allow much air to enter beside the wire, may require more effort. Try moving the iron in a circular motion so that the solder is thoroughly melted before tapping the switch. Small plated-through holes with old solder sometimes require a second pass after refilling the connection with fresh solder. The top plane of ground-plane boards occasionally soaks up so much heat that the top side doesn't melt; in this case, add heat to the top side with a soldering iron while desoldering the lead. However, most connections won't take this much effort.

After desoldering all leads, take a pair of long-nosed pliers and wiggle each

lead to break any "skin" of solder that may remain. Your component can then be removed.

The vacuum desolderer is the best tool I've found for printed-circuit lead removal, but don't throw away your other tools. Some connections still respond better to other methods. For instance, large terminals are best handled with a pump. And sometimes the best way to handle double-sided plated-through holes is to get as much solder out with the vacuum iron as possible, then remove the rest with braid. The hollow-tip iron doesn't work well on surface-mount components, although it can remove some of the solder as a first step. With practice, the procedures become natural.

Remember to repump the vacuum when it drops to 15 inches or so. The higher vacuum does a better job of desoldering, and it also breaks the solder into smaller granules, making iron maintenance easier.

Maintenance

Solder will have to be cleaned out of the iron periodically. Although many

solder granules end up in the filter, some solidify in the metal tube of the iron. When the tube gets too full, the vacuum gets choked off and desoldering performance declines. To clean the iron, remove the hose and run a 5/32-inch drill bit up the tube, holding the end over a trash can while the solder shavings fall out. Drill slowly and carefully and hold the tube and body of the iron with pliers. Be cautious—I once pushed the drill bit in too far and drilled right out through the end of the tube. Maybe someday a better iron will be available with an easier-to-clean reservoir.

If a wad of solder becomes stuck in the hose, remove the hose and push a rod or coat hanger wire through to clear it. The hollow desoldering-iron tip eventually will wear out, but replacements should be readily available. I've had to disassemble and clean a solenoid and the small pump once in five years of use, so those parts have been pretty reliable. In that time, I've worn out two irons and a dozen or so tips, so I've desoldered a lot of connections with this system.

ES&T

You told us what you wanted ...and we listened to you!

Over the past year you've given us your suggestions through letters, phone calls and by answering our research questionnaires. And here's what you said and what we've done for you.

You told us to publish:

- More VCR servicing articles.
So, now ES&T gives you *Video Corner*—VCR servicing how-to information every month.
- More computer servicing articles.
So, now ES&T gives you *Computer Corner* computer servicing information every month.
- More audio servicing articles.
So, now ES&T gives you *Audio Corner*—how-to servicing tips every month on repairing CD players and other audio equipment.

Plus, you said to publish:

- More *Symcures*.
So, back by popular demand, you'll find *Symcures* in ES&T every month—providing you the symptoms and cures compiled from field reports of today's most recurring equipment troubles.

And, you said to give you more information on:

- Servicing *automotive electronics*.
- Locating *replacement parts*.
- Finding *servicing documentation*.

Again, we've listened to you. And, ES&T will publish more of what you want and need to read about during the next few months and throughout all of 1989.

That's why now, more than ever, you can't afford to miss your next issue of *Electronic Servicing & Technology* magazine.

So, renew your subscription today. Don't delay. Use your handy subscription renewal form on page 29 in this issue. It's postage-paid for you to return to ES&T, so it won't cost you a cent.

Renew your subscription now. Because, now more than ever, ES&T is delivering what you want and need to read to succeed in your business.

The how-to magazine of electronics...

ELECTRONIC
Servicing & Technology

Taking your VCR with you

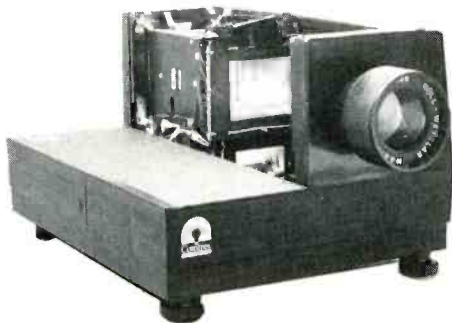

This cutaway model shows the LCD in operation. The high-resolution 100,000 transistor LCD panel acts as an electronic slide.

If you were a traveling salesman or corporate trainer, one problem you would run into is, how do you show your sales or training tapes to a large group of people? Although VCRs may have a big advantage over 16mm projectors, the one big disadvantage is that they can't be considered portable. You would have to bring along the VCR and a television, but the groups you dealt with would be limited by the size of the TV screen. Of course, if your customers came to you, you could use a VCR to show videotapes on a big-screen TV.

Big screen, small package

One future possibility is a portable color projection TV that will be marketed by Comtrex International. The 6-pound unit, named Crystal Vision, uses a miniature internal color liquid crystal display to project a TV picture up to 10 feet. A projection TV, VCR and 16-inch screen will allow users to make a group video presentation from a single briefcase.

The image is illuminated by intense

white light from an 8,000-lumen halogen source that passes through the LCD, where the image is created by nearly 100,000 discrete picture elements. Thin-film technology allows each picture element to be driven by its own transistor, which results in a 60-to-1 contrast ratio and fully saturated colors.

After the image is created, it is focused and projected on any suitable surface by interchangeable, optically coated multi-element lenses. (Wide angle or long focus lenses are available.) The projected image is 6 inches to 18 feet diagonal, depending on the lens con-

figuration. The unit also includes proprietary filters and fan-driven cooling.

Three versions

The company is initially planning three models. The simplest, the CVP-100, is a stand-alone video projector that can accept video input from a video camera or VCR. The CVR-200 adds a VHF/UHF tuner and rabbit-ear antenna. The CVP-300 adds a self-contained, top-loading VHS videotape unit and tuner. The company will also offer custom configurations for large-volume customers.

ES&T

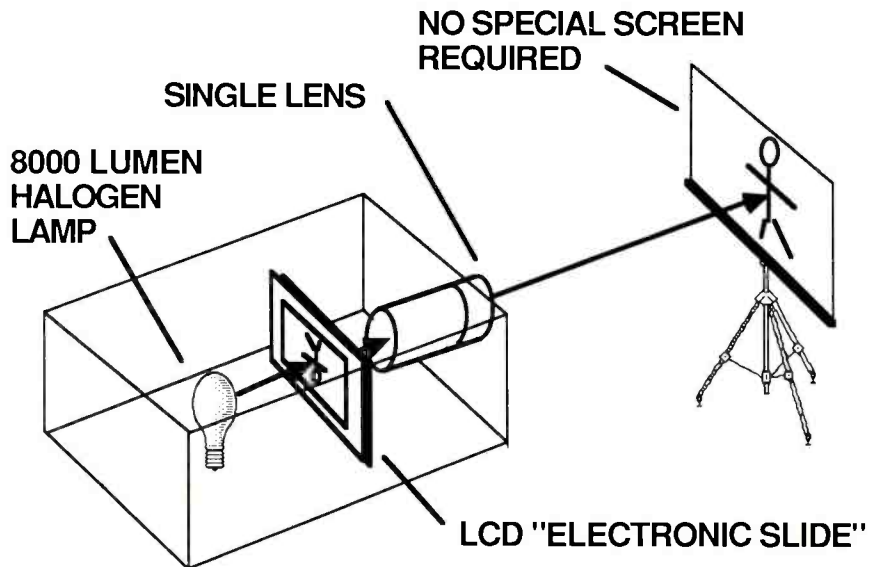
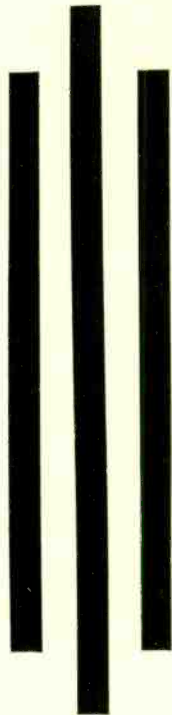

Figure 1. The portable color projection TV uses an 8,000 lumen halogen lamp and a single lens to achieve a high-resolution image without complicated optics or convergence.

Quiz answers

Questions are on page 16.



1	B	2	U	3	F	4	F	5	E	6	R	7	S				8	T
9	U							10	A	L	T							E
11	L	A	N	S						12	O	P	E	N				
15	K									16	E	R	I	E				
		17	S	18	T	19	E	20	P	P	I	N	G					
			21	T	U	N	E										22	D
23	P	E	R					24	R	B	G							I
			26	P	B									27	O	P	L	A
29	I	S				30	T	31	R	O	P	I	C					
	O					33	S	O	F	T	W	A	R	E				

**12000V FOR THE
BRIGHTEST TRACE!**

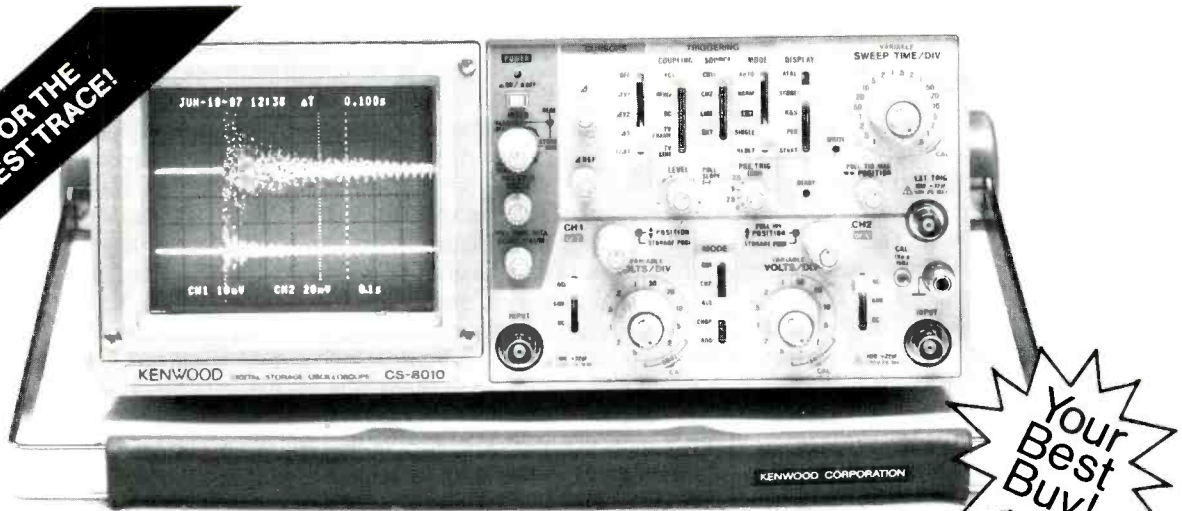

**CS-8010 Digital Storage Scope is FASTER,
with a brighter CRT readout and more memory.**

- 10 megasamples per second sampling speed.
- 20MHz Real Time.
- 8-bit vertical resolution and 2048 word-deep memory for each of two channels.
- Storage function provides easy waveform observation of one-time events and transient signals.

- Cursor functions provide digital measurements of voltage, time, frequency and phase difference.
- Screen readout displays such vital data as vertical axis sensitivity and sweep time settings.

For more information, contact your Kenwood Distributor or call Kenwood today!

KENWOOD

KENWOOD U.S.A. CORPORATION
Communications & Test Equipment Group
2201 E. Dominguez Street
Long Beach, CA 90810.
P.O. Box 22745.
Long Beach, CA 90801-5745.
Telephone: (213) 639-4200

Specifications are subject to change without notice or obligation.

Circle (12) on Reply Card

See Us At Weston/'88 Booth Nos. 24, 26, 36, 37

November 1988 *Electronic Servicing & Technology* 41

What do you know about electronics?

The Norton generator

By Sam Wilson, CET

A Thevenin generator is made up of a source that has no internal resistance, and it includes a series-connected resistor. The series resistor imitates an internal resistance.

Thevenin's theorem (see October's "What Do You Know About Electronics") says that *any* 2-terminal active network can be replaced by a Thevenin generator. (See Figure 1.) It doesn't matter how many sources of voltage are in the 2-terminal circuit. (There must be at least one.) It doesn't matter how many resistors and battery internal resistances are in the circuit. You can *always* replace the 2-terminal circuit with the Thevenin generator.

The Norton generator

Figure 2 shows the Norton generator. Like the Thevenin generator, it can be used to replace any 2-terminal active network. It uses a *constant-current* generator and a single resistor.

If you look into the Thevenin generator, you see R_{th} because the battery has no internal resistance. It is a *constant-voltage* generator. The value of R_{th} is the same as the combination of all resistance values in the 2-terminal circuit.

It follows that $R_{th} = R_n$ because the Norton generator can be used to replace the same active circuit. The only way you could see R_n to be the same value as R_{th} is for the internal resistance (or impedance) of the Norton generator to be infinitely high.

Therefore, the Thevenin source has zero internal resistance and the Norton source has an infinitely high internal resistance. Neither is possible in the real world, but they are very useful as an aid to understanding electronic circuits.

If the Thevenin and Norton circuits are both equal to the same active

2-terminal, then it follows that they are related to each other. The relationship is simply Ohm's law. If we were into math we would say

$$I_n = V_{th}/R_{th}$$

where $R_{th} = R_n$. Figure 3 shows how the Thevenin and Norton generators are related.

So what?

By now you are surely wondering if any of this has any real meaning. The answer is that the theorems and laws are tricks of the trade. They are used for simplifying circuits so that they are more easily understood. They are examples of models. Also, they make mathematical calculations of circuit outputs much more simple.

The maximum power transfer theorem is a good example. It explains why speakers should be matched to an amplifier through an impedance-matching transformer. The transformer permits the amplifier to look into an ideal impedance. Likewise, it permits the speaker to be connected to a generator that will provide it with a maximum power. In a similar way, Thevenin's and Norton's generators provide a simple way of looking at complicated active networks.

The 4-terminal (passive) black box makes it easier to understand the problem of matching transmission lines. When ac is assumed for the input and output, the 4-terminal circuit simplifies the understanding of filter circuits. Resistive matching pads (attenuators) are based upon the equivalent T or TT circuits for 4-terminal problems.

We *could* get involved with the actual calculations for each of the types of problems that are more easily solved by the use of theorems. That would help to make their use in design more clear. However, the purpose of this series is

to explain what the network theorems and laws are used for, not how they are used.

Active 4-terminal networks

In an earlier discussion, the idea of 4-terminal passive networks was discussed. Now, what if there is a source of voltage or current inside the black box? Then it becomes an *active* 4-terminal network.

When the network in the black box is passive, it can be completely described by taking input and output resistance measurements: the input resistance with the output terminals open, the input resistance with the output terminals shorted and so on. Those measurements are called the *R parameters*, and Figure 4 shows how they are made. They are also known as the ABCD parameters, depending upon who is doing the writing. If the network has reactive components—that is, inductors and capacitors—impedance parameters are used instead of resistive parameters. They are known as the *Z parameters*.

Regardless of the type of parameters, the same types of measurements can be made: input with output open, input with output shorted, output with input open, output with input shorted. That is also the way the active parameters are determined. There is an important exception that will be explained later in this article.

So, you can measure input and output voltages under the four conditions shown in Figure 4. That will give you V parameters (or v parameters if the voltage sources in the black box are ac).

You can get I or i parameters by measuring input and output currents under the conditions shown in Figure 4. If you measure V and I, you can divide to get Z parameters. (Make those v and i measurements and you get z parameters.) Last, but not least, you can invert

Wilson is the electronics theory consultant for ES&T.

ATTENTION VCR TECHNICIANS



VCR REPAIR PARTS KIT

Now you can do most of your VCR repair jobs the **same day**. Parts Express VCR Parts Kit makes this possible. It contains over 45 of the most commonly used parts to repair RCA, Hitachi, Fisher, Sanyo, Lloyds, Panasonic, Sony, Sharp, JVC, Samsung, TMK, GE, Magnavox, and more. Idler assemblies, pinch roller, sensing transistors, switches, and lamps are included in this comprehensive kit. You also save over \$20.00.

Kit contains replacements for: Sharp (2) NIDL0005, (2) NIDL0006, (1) NPLY-V0051, Panasonic (2) VXP0329, (2) VXP0401, (2) VXP0344, (2) VXP0521, RCA (1) 150614, (1) 164113, (1) 150650, Hitachi (1) 641311, Fisher/Sanyo (1) 143-0-4204-00300, (2) 143-0-4804-00100, (1) 143-0-4904-00900, (1) 143-0-7411-20002, RCA/Hitachi (2) up/down switch, (5) 161757 sensing transistors, Panasonic lamps, (2) XAMQ2P150W, (5) XAMV0019, (5) XAMV125, (1) Molybdenum grease. Normal dealer cost of over \$110.00. (All parts are available individually for reorders.)

Order #
400-950

\$89⁹⁵
Plus shipping



VCR IDLER TIRE KIT

This popular kit contains 150 of the most popular idler tires (10 each of 15 different sizes). With this kit in your stock room, you can do over 90% of VCR repair jobs the same day, saving time and money! Also included is our comprehensive cross reference listing over 80 manufacturers' assembly numbers and over 200 model numbers. A \$400.00 retail value. (All tires are available individually for reorders.)

Order #
400-900

\$55⁰⁰
Plus shipping

**FREE
CATALOG**



**Parts
Express**
International Inc.

CALL TOLL FREE
1-800-338-0531

340 E. First St., Dayton OH 45402
Local—1-513-222-0173

Circle (13) on Reply Card

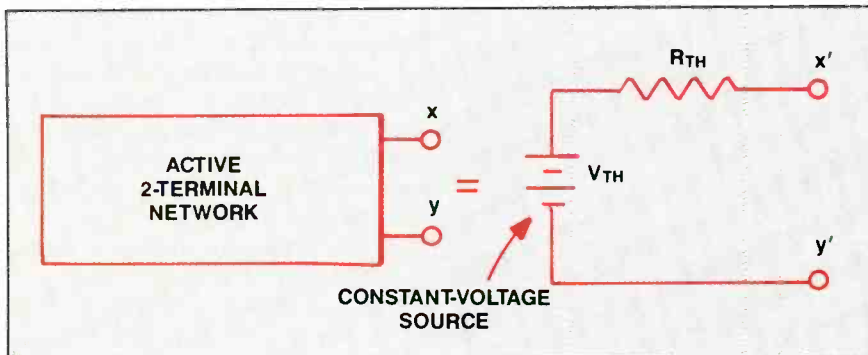

Figure 1. Any 2-terminal active network can be replaced by a Thevenin generator. It doesn't matter how many sources of voltage are in the 2-terminal circuit. (There must be at least one.) It also doesn't matter how many resistors and battery internal resistances are in the circuit.

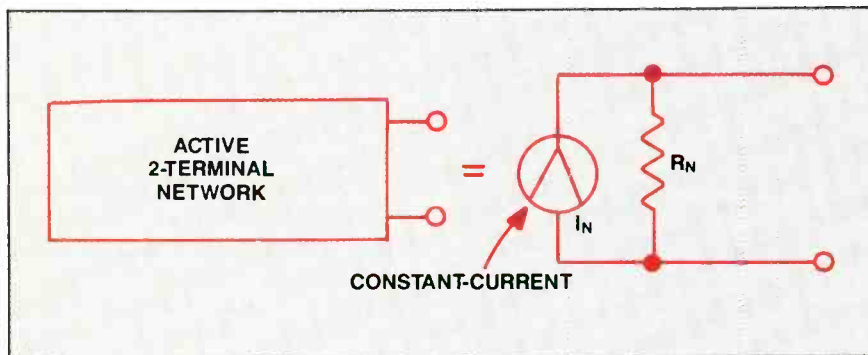

Figure 2. Like the Thevenin generator, the Norton generator can be used to replace any 2-terminal active network. It uses a constant-current generator and a single resistor.

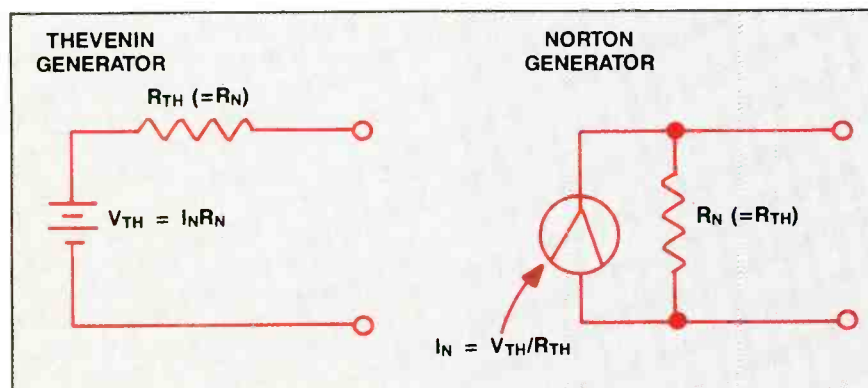

Figure 3. If the Thevenin circuit and the Norton circuit are both equal to the same active 2-terminal, then it follows that they are related to each other. The relationship is simply Ohm's law: $I_N = V_{TH}/R_{TH}$ where $R_{TH} = R_N$.

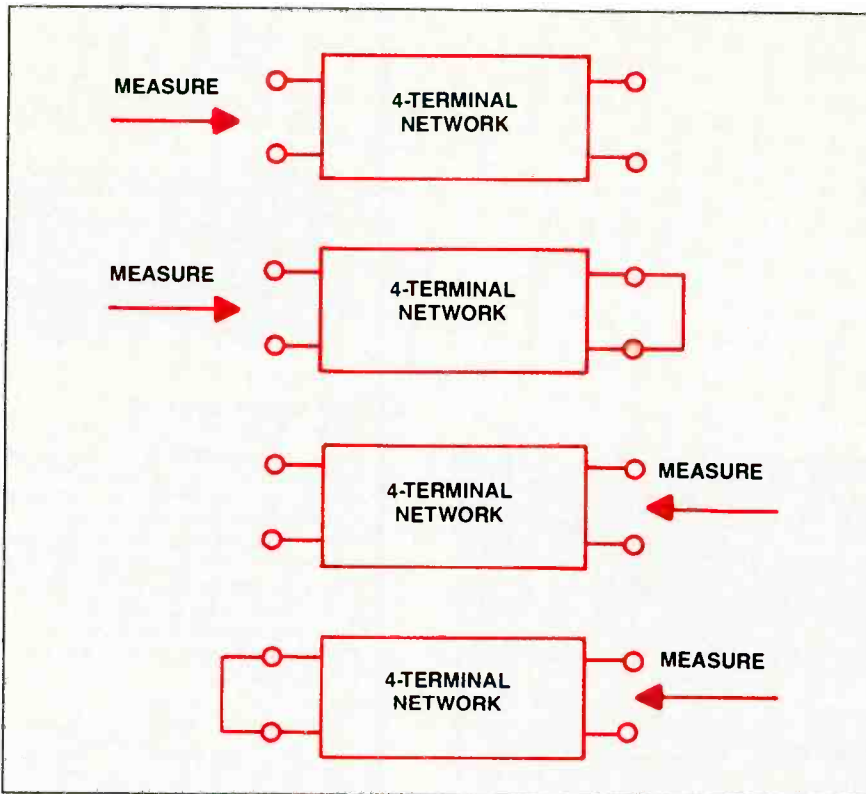

Figure 4. When the network in the black box is passive, it can be completely described by taking input and output resistance measurements. Those measurements are called the R parameters.

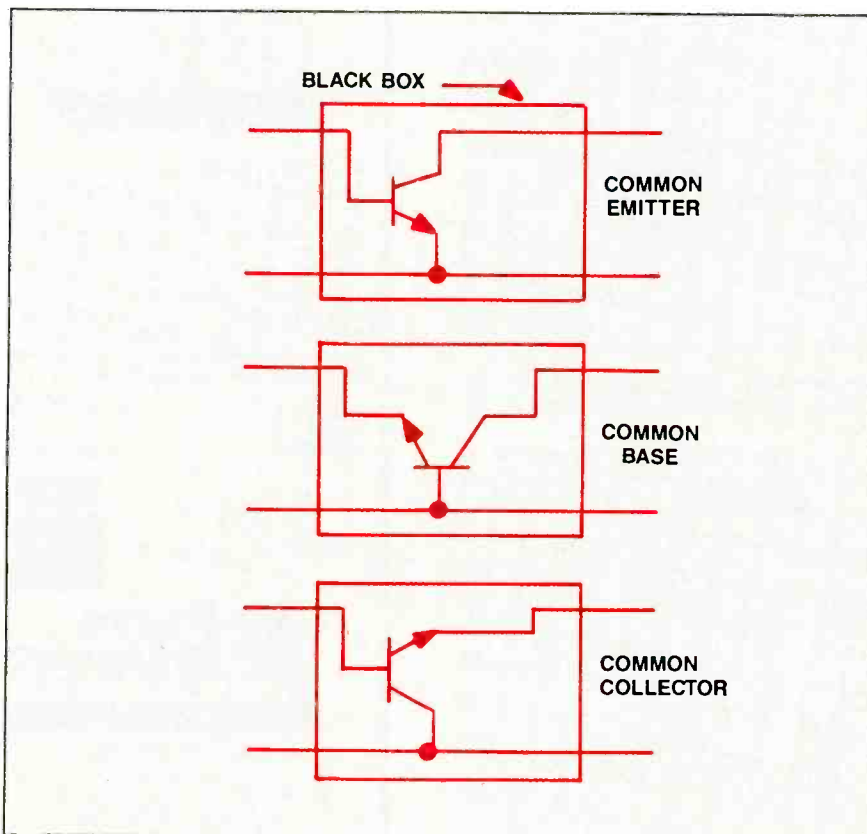

Figure 5. Hybrid transistor parameters are made possible by treating a transistor as if it is in a 4-terminal black box. Any linear 3-terminal device can be configured in the same way as the transistor shown here.

R (resistance) to get G (conductance), so you can have G—or conductive—parameters.

The reciprocal of impedance (Z) is admittance (Y), so you can also have admittance or Y parameters if the source inside the black box is ac.

Depending on the teacher or professor, or who wrote the book, or who is paying you, you can get involved with any or all of these parameters. All are for the purpose of simplifying the 4-terminal networks.

The h parameters

Hang on! There is one more type of black-box parameter that you should know. Up until now, we've concentrated only on input and output measurements. But what if you do something crazy like measure the output voltage and the input current? You can easily make four measurements like that.

We could call them crazy parameters. However, they are really known as *hybrid parameters* or *h parameters*. Just as you can get hybrid corn by mixing two kinds of corn, you can get hybrid parameters by mixing two kinds of V and I parameters. This explains the following hybrid parameters that you are sure to run across sooner or later:

$$\begin{aligned}
 h_{fe} &= \beta_{ac} = \text{ac beta} \\
 h_{FE} &= \beta_{DC} = \text{dc beta} \\
 h_{ih} &= \alpha_{ac} = \text{ac alpha} \\
 h_{FB} &= \alpha_{DG} = \text{dc alpha}
 \end{aligned}$$

These *hybrid transistor parameters* are made possible by treating a transistor as if it was in a 4-terminal black box. (See Figure 5.) Any linear 3-terminal device can be configured in the same way as the transistor in Figure 5.

Remember, a transistor is treated like an active component. It is thought to be the source of the ac signal, which is why the ac parameters are usually used.

Why is this so important? The reason is that knowing the transistor h parameters makes it a simple matter to design a transistor circuit as if it were a basic black box. Again, the purpose is to simplify calculations.

These hybrid parameters are carried over to the technician world because they are important ways to evaluate the transistor. If those parameters don't measure correctly, the transistor won't work in a circuit that was designed for those parameters.

Thus, you have the Beta checker.

ES&T

Literature

Tech book catalog

The UTC 1988/89 catalog from the *United Techbook Company* lists 3,000 of the most widely accepted handbooks, directories, textbooks, databooks, sourcebooks, encyclopedias and dictionaries in forty categories, from control system design or computer architecture to desktop publishing and tax accounting. The catalog also describes a free bookfinding service, low-cost library software, and a High Tech book update service.

Circle (125) on Reply Card

Test and measurement catalog

Leader Instruments is offering a 96-page catalog describing more than 100 test and measurement instruments. The catalog includes a glossary of oscilloscope terms and application notes on digital and analog oscilloscopes, video products, programmable RGB video generators and frequency counters.

Circle (126) on Reply Card

Test equipment product guide

Leasametric has introduced an expanded product guide for test equipment the company offers for rental, lease or purchase, either new or used. The 175-page guide has product indices, a manufacturer's index, specifications and selection information for test equipment from more than 80 manufacturers. Products include analyzers, measurement instrumentation, meters, microwave equipment, oscilloscopes, power supplies, telecommunications test equipment, microprocessor test and development systems and more. The company can usually deliver the equipment within 24 hours of the order and offers various financing programs.

Circle (127) on Reply Card

Test equipment catalog

Anasco's catalog of test and measurement equipment features more than 100 new products and offers technical information on more than 1,000 electronic test, service and measurement products. The 56-page catalog contains specifications and selection guides for multimeters, calibrators, power supplies, frequency counters, function generators, chart recorders, oscilloscopes, breakout boxes and service supplies.

Circle (128) on Reply Card

ESD product catalog

The "Static Elimination Systems and ESD Products" catalog from *Chapman* outlines the company's static elimination equipment, including the traditional electrical ionizing bars and passive devices. The catalog also emphasizes the company's ESD product line, including bench-top ionizers, static meters and residual voltage meters.

Circle (129) on Reply Card

Equipment catalog

The *Eraser Company* is offering its 16-page "Short Form Catalog," which features most of the company's production equipment for the electronics industry. Equipment applications include wire cutting, stripping, dereeling and printed circuit board production. The catalog also features the company's line of FyBRglass industrial brushes for cleaning and burnishing.

Circle (130) on Reply Card

Components catalog

Newark Electronics is offering a 1,040-page catalog that provides dimensions, specifications and descriptions of more than 100,000 items from more than 230 manufacturers of electronic components. The catalog includes 19 new vendors and more than 9,000 new items. All items are delivered from stock.

Circle (131) on Reply Card

DMM/accessory selector guide

The Instrumentation Products Division of *Beckman Industrial* is offering a selector guide describing the company's latest line of digital multimeters and accessories. The catalog describes the heavy-duty series of DMMs, the professional series and the Circuitmate and Circuitmate Super Economy series, plus a new analog VOM/multitester and a new pocket-size meter.

Circle (132) on Reply Card

Parts/components catalog

MCM Electronics' catalog contains more than 11,000 parts and components, including 500 introduction items. Among the categories described are semiconductors; computer equipment; power centers and regulators; telephone parts; connectors; TV, audio and VCR parts; tools; and the company's proprietary line of TENMA test equipment.

Circle (133) on Reply Card 

HITACHI SCOPES

15-25% Discount



V1060
100MHz
\$1285

V660 60MHz Dual Trace \$949
V422 40MHz Dual Trace \$699
V212 20MHz Dual Trace \$379

ELENCO PRODUCTS AT DISCOUNT PRICES!



\$498
MO-1252

Scopes

MO-1252 35MHz Dual Trace \$498
MO-1251 20MHz Dual Trace \$349
w/ Two 1x, 10x 100MHz probes, manual
S-3000 10MHz fully calibrated \$239
P2 Scope Probe 100MHz \$23.95
P1 Scope Probe 65MHz \$19.95

GF-8016 Function Generator with Freq. Counter

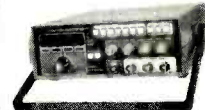

\$239.95

Sine, Square, Triangle
Pulse, Ramp, .2 to 2MHz
Frequency .1 thru 10MHz

GF-8015 without Freq. Meter \$179

Digital Triple Power Supply

Model XP-765 \$239.95



0-20V @ 1A
0-20V @ 1A
5V @ 5A

Fully Regulated, Short Circuit Protected
with 2 Limit Cont. 3 Separate Supplies
XP-660 w/ Analog Meters \$169.95

Color Convergence Generator



SG-200

\$69.95

Finest in the industry
10 rock steady patterns

Digital LCR Meter

\$138.95

Model
LC-1800

Measures
Inductors,
Capacitors,
Resistors



Multimeter with Cap. and Trans. Tester

\$55.95

Model
CM-1500A

8 Functions
with Case



C&S Sales Inc., 1245 Rosewood
Deerfield, IL 60015 (312) 541-0710
800-292-7711 ASK FOR CATALOG

15 Day Money Back Guarantee
2 Year Limited Guarantee
Add 5% for Postage (\$10 max)
IL Res., 7% Tax



Circle (14) on Reply Card

Troubleshooting low-voltage IC regulators

By Homer L. Davidson

Linear IC low-voltage regulators appear identical to standard power transistors of TO-3 or TO-220 dimensions except that each has one or two extra terminals. The extra terminals indicate a regulator with more inside than the usual power transistor. Also, the words *integrated circuit* imply additional IC-type components. This article explains what is inside typical IC regulators and how to test them, both in circuit and out.

What is it?

Just when we technicians think we thoroughly understand the power-transistor low-voltage B+ regulator, and we believe the circuit has no surprises for us, we find something that jars our complacency. An unexplained device is in the low-voltage power supply where a

power transistor traditionally is placed, but it has three leads instead of the usual two. (See Figure 1.) Therefore, there is little possibility that the device is a transistor. So what is it?

A quick search of schematics and solid-state replacement guides shows that the device is some type of linear IC voltage regulator—for one specific dc voltage. IC component numbers that begin with STR or IC for voltage regulators seldom need or have B+ variable resistors in the circuits for accurate trimming of the B+ voltage. Instead, the output voltage is determined and stabilized by reference to an internal zener diode in each IC. Therefore, replacement STR and IC voltage regulators are selected for the desired dc output voltage. These regulating ICs are available for B+ output voltages of 115V, 123V, 125V and 130V. If substitution is nec-

essary, use the next lower voltage (not higher).

Incidentally, these pseudo-transistor regulators were used extensively in many foreign-built portable television receivers between 1982 and 1987.

Stand-by power circuits

Color televisions with remote control usually have full power applied to the remote-control receiver (at least all the time the television is plugged into ac power). Sometimes these are called *stand-by circuits* because they are powered and ready at all times, awaiting activation by signals from the remote control. However, the TV receiver is not powered unless commanded by the remote control.

One major function of the remote control and stand-by circuits is turning on and off the TV receiver's B+ power (+145V for picture with sound, 0V for no raster and no sound).

During stand-by time, we can measure +12V, +5V and 120Vac at the proper points, but the +145V source is missing, so the TV receiver is dead. The principal B+ supply for this model television receiver is +145V (produced by D_{802} and C_{851} in Figure 4).

A minimum amount of testing will prove the 120Vac for D_{802} is blocked by the open contacts of RL_{01} relay. A jumper wire attached temporarily across the RL_{01} contacts should restore picture and sound if the only problems are with Q_{A16} or relay RL_{01} .

Operation of the relay and Q_{A16} merit a short explanation. Positive collector current for Q_{A16} comes through the RL_{01} relay coil from filter capacitor C_{A21} . The Q_{A16} base voltage should have a LOW when the receiver is off and a HIGH when the receiver is to be turned on. These LOWs and HIGHs are voltages that come from the remote-control circuits, and they can be measured on the dc-voltage ranges of a DMM. A HIGH at the Q_{A16} base causes collector current to close the relay contacts, and the +145V source is

Davidson is the TV servicing consultant for ES&T.

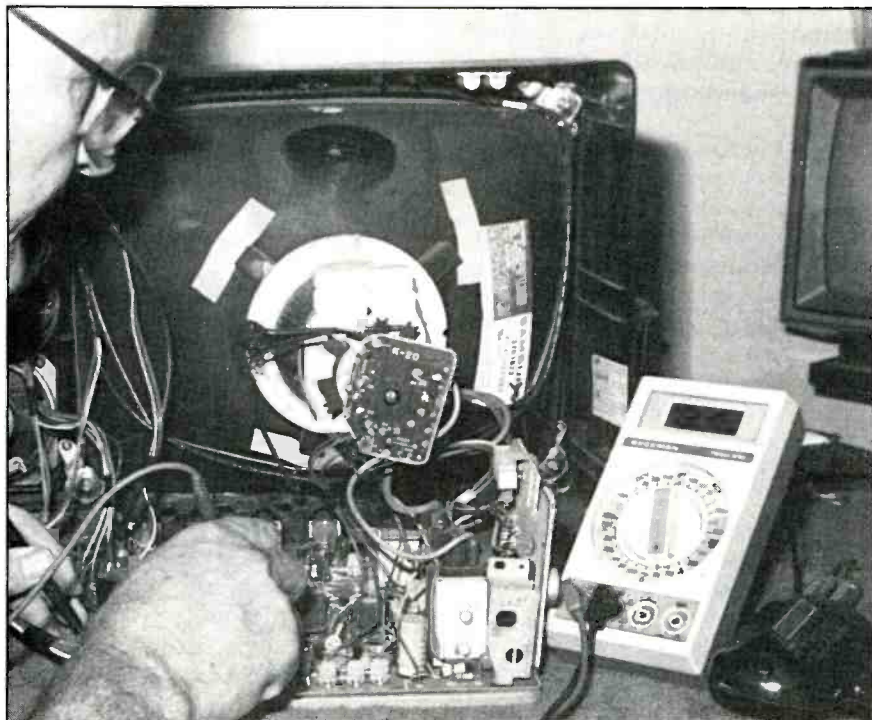

For testing resistors in solid-state circuits, a DMM is the best choice. The ohmmeter voltage is so low that it usually does not cause unwanted conduction in solid-state components, allowing the technician to perform more accurate resistive tests without wasting time disconnecting leads.

The IC regulator

In the CT-333KA Samsung portable TV, a power-supply source of about +155V is connected to Q_{801} (the STR382 IC regulator in Figure 1). A regulated output of +125V from the IC is supplied to the Q_{404} horizontal-output transistor, the flyback transformer and the sound circuits. All other operating dc voltages are obtained by rectifying horizontal signals from secondary windings of the T_{444} flyback.

Line voltage of 120Vac is applied to diode D_{802} (on the main chassis board), and C_{851} is included to make the rectified voltage peak-reading. After subtraction of small voltage drops across R_{804} and safety resistor R_{802} , the remaining +155V is applied to the collector of Q_{801} . A 1.2A fuse (F_{802}) is connected between R_{802} and R_{804} . (See Figure 1.) If this fuse is blown, look for leakage in Q_{801} or an overload in the horizontal-output circuits.

Q_{801} , the B+ IC regulator, has the physical appearance of a horizontal-output transistor, except it has three terminals, not the usual two (Figure 1A). Apparently each Q_{801} IC has the usual power-transistor base, emitter and collector connected to the proper terminals. However, the addition of a ground (or

FIGURE 1A

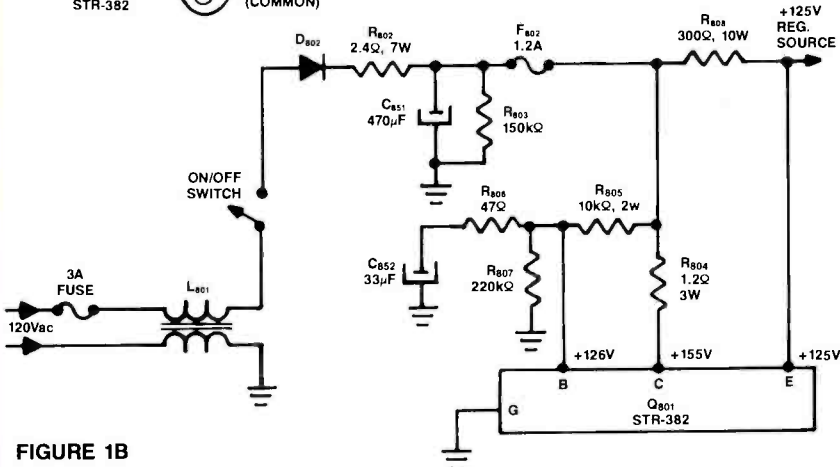
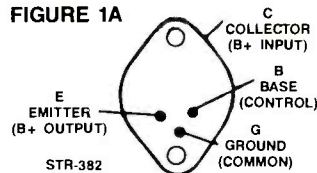

FIGURE 1B

Figure 1. Q_{801} , the B+ IC regulator of the Samsung CT-333KA portable, has the physical appearance of a horizontal-output transistor, except it has three terminals, not the usual two (Figure 1A). However, the STR-382 IC probably contains diodes, transistors and resistors in addition to the power transistor. A B+ adjustment control or an external voltage-stabilizing zener diode is not required, according to the Figure 1B schematic.

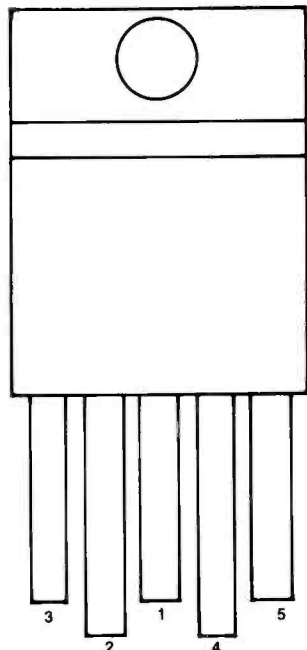

FIGURE 2A
STR-30125
IC REGULATOR'S
TERMINALS

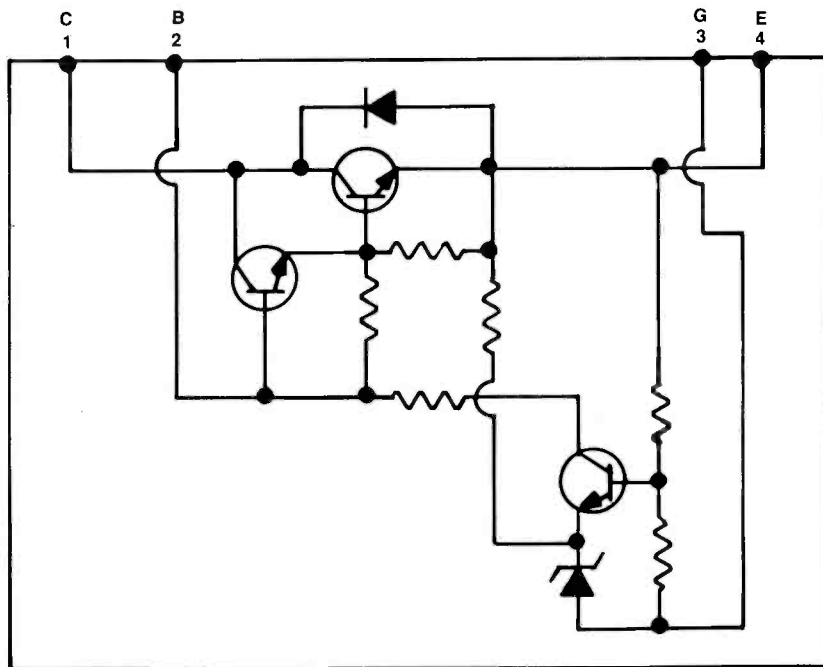

FIGURE 2B

Figure 2. Except for the five terminals instead of the usual three (Figure 2A), STR-30125 regulators resemble TO-220 types often used for vertical-output transistors. An equivalent of the IC's internal circuitry, using transistors, diodes and resistors, is shown in Figure 2B.

power-up the TV by using the on/off switch or the remote transmitter. Measure the dc voltage from Q_{A16} collector to ground. This voltage is higher when the TV is off and lower when it is on. The voltage normally ranges between +13V and +17V. Notice if the relay contacts close when ON is selected. If the remote-control and pre-amp circuits are operating correctly, the relay should energize at that time and close the contacts. If not, measure the resistance of the relay's winding. Is it open? Disconnect one lead of paralleling diode D_{A24} and check for correct diode action or excessive leakage. With a transistor tester, check Q_{A16} , the relay-drive transistor. If none of these actions uncover the problem component, test other allied circuits.

When the collector of Q_{A16} has an abnormal dc voltage, check Q_{A16} , Q_{A17} , Q_{A18} and Z_{DA4} . Push the power button and notice on a DMM if a normal HIGH is produced at IC01 pin 28. The HIGH is required to turn on Q_{A16} . If the HIGH is missing, check Q_{A17} , Z_{DA4} and IC101. If the HIGH appears at pin 28 but the receiver has no power, suspect a defective Q_{A16} transistor, D_{A24} diode or RL_{01} relay.

Determine whether the main TV chassis is defective or normal by clipping a short test lead between terminals 1 and 2 of P_{A10} in the stand-by circuitry. (The same results are obtained if you short between terminals 24 and 25 of the main TV chassis. Or short together the RL_{01} contacts.) Shorting across these points applies 120Vac to D_{802} and should provide picture and sound if the TV chassis is normal. If the primary defect is in the TV receiver, however, the receiver might have no picture, sound or raster.

Replacing IC regulators

IC low-voltage regulators usually should be replaced only with one of the same part number. If the original part is not available, universal IC regulators can be used. Although the supply of IC voltage regulators is very small, RCA lists four different fixed-voltage types in the 1987 SK series replacement manual. At the present time, many higher-numbered STR voltage-regulator ICs cannot be replaced with universal replacement devices. Original-part-number ICs must be used. (See Table 1.)

Remember, regulators have three basic forms. One is the STR that is mounted with two screws and has the appear-

Coming Up In...

ELECTRONIC

Servicing & Technology

December

Replacement Parts

Finding the correct replacement for a failed part is one of the biggest problems facing electronic servicing technicians. ES&T provides you with information on where to find replacement parts, and where to get information on selecting and obtaining replacement parts.

Changes in Consumer Electronics Servicing

Consumer electronics servicing has changed over the years. ES&T describes the increase in sophistication of the technician and the equipment needed to cope with these changes.

January

Personal Computer Servicing--Special Report

The number of personal computers found in homes and offices is constantly increasing. ES&T addresses the specific problems that plague personal computers, and explores ways to correct the problems when they occur. You'll also learn about the role depot repair, breakout boxes and logic probes play in servicing personal computers.

Technology Update--DAT

Digital audio tape is a technology that promises to deliver the audio quality of compact disc, but adds the ability to record at home with near perfect sound quality. This ES&T article will describe for you the current status of this technology, and explore how it differs from existing tape recorders.

February

VCR Servicing--Special Report

This ES&T special report discusses VCR technology. How they work, how they're constructed, how to go about diagnosing problems in them, and how to service them.

Satellite TV Servicing

ES&T looks at the components of a satellite system. You'll learn how they're interconnected, and how to isolate the problem to a specific component when malfunctions occur.

Plus ES&T's Regular Monthly Departments

STR regulator number	RCA replacement number	Sylvania replacement number	dc output voltage
STR380	7646	1548	123Vdc
STR381	7647	1546	130Vdc
STR381A	7647	1546	130Vdc
STR383	7719		120Vdc
STR385	7720	1553	127Vdc

ance of a horizontal-output transistor. The second type mounts flat; it's almost the twin of a vertical-output transistor but with more leads. Other IC low-voltage dc regulators resemble conventional power-output ICs, and they mount on a heat sink.

When a replacement is needed, look up the STR number in the universal-transistor manual to see if a universal replacement is available. It's possible, under certain conditions, to substitute another STR regulator—if the output voltage is slightly lower than the original. For example, if the schematic calls for +125V, a universal SK7646 with +123V should work fine. But do not substitute a regulator with a higher output voltage than +125V because the higher voltage could cause shut-down. Remember that an appropriate replacement for a low-voltage IC regulator should have the exact output voltage and all the physical features matching the originals.

Measure all regulator leakages from terminal to terminal. Then, for each diode or transistor junction (that is accessible from the outside), perform the DMM diode test. In this test, a constant flow of current is forced through the diode or transistor junction while the digital readout displays the resulting dc-voltage drop (up to 1.99V) across the junction. Readings near zero show a shorted junction; an overrange display indicates an open junction. Silicon transistors usually test between 0.6V and 0.9V, according to types. Two junctions that are connected correctly in series (as in a Darlington transistor) will show a doubled voltage reading between base and emitter but a normal voltage between base and collector.

To prove whether the out-of-circuit STR-382 voltage-regulating IC is defective, test the regulator IC by connecting the DMM diode-testing probes to the terminals shown in Figure 5. The junctions should produce approximately the following dc-voltage readouts:

- Positive probe to base, negative probe to emitter = 1.162V.

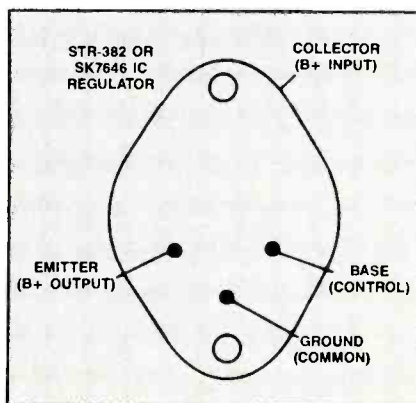

Figure 5. Not all good test-points of a voltage-regulating IC are brought out to terminals. Therefore, many tests are not possible from the outside terminals. Fortunately, only three of the possible tests are often sufficient to prove whether the out-of-circuit IC is defective.

- Positive probe to base, negative probe to collector = 0.633V.
- Positive probe to emitter, negative probe to collector = 0.677V.

Other combinations of terminals activate the overrange signal, possibly indicating an open circuit or a reverse-biased junction. (Reverse the test-lead polarity and try other pairs of terminals.) Any major deviation from these three readings labels this IC as defective or questionable, needing more tests.

Remember that VOMs or ohmmeters are not satisfactory for the previous tests. Readings sometimes can be obtained with them, but some are not dependable and others have no meaning. Also, ohmmeters cannot provide trustworthy reversed-bias readings of any IC-regulator terminals because of the unknown-value internal resistors. Therefore, normal leakage cannot be measured, and the ohmmeter's most important function is to find severe shorts or strong leakage inside an IC regulator.

Troubleshooting regulator circuits

Before you attempt to service any ac line-powered TV circuits, plug the portable TV into an isolation-type variable-voltage transformer for safe ac power. Otherwise, a non-isolated variable transformer can be dangerous to technicians, test equipment and the TV under repair. The problems center around receiver circuits with hot grounds and test equipment with 3-prong ac plugs that automatically ground the equipment.

For the first step in locating the source of low-voltage regulator failure, measure the dc voltage at the output of the IC regulator (or at the collector terminal of the horizontal-output transistor). Very low or incorrect dc voltage might point to a defective low-voltage power supply or an overloaded horizontal-output circuit. Remove the horizontal-output transistor if it can be removed by two machine screws. At the least, always remove the collector wire if the transistor is mounted to the heat sink with two screws and nuts.

Next, measure the dc voltage at the IC regulator's input terminal (or at the fuse if one is located between the line-voltage rectifier and the regulator). This

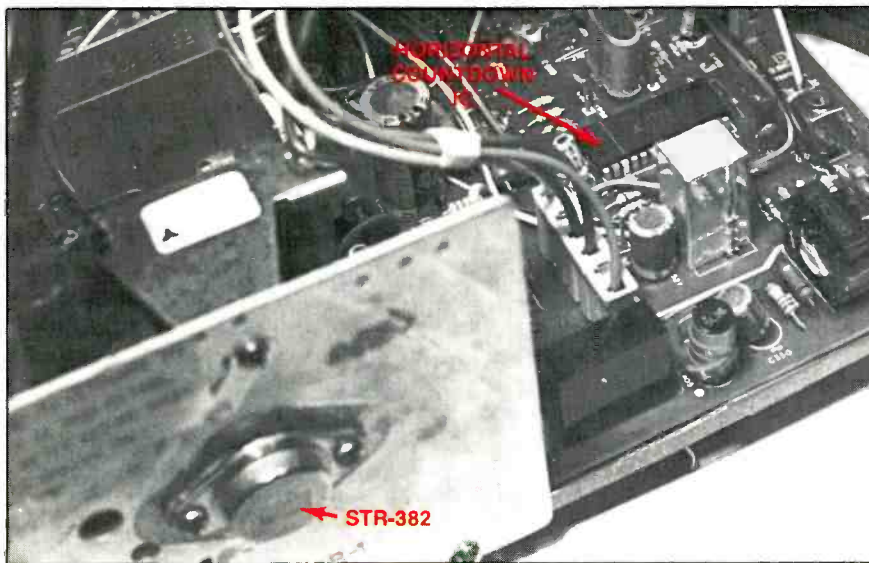

When the low-voltage-regulator output is normal but the horizontal circuits are overloading, scope all waveforms at the horizontal countdown IC and the driver circuits that follow. The basic problem must originate in the horizontal circuit, so keep on testing there.

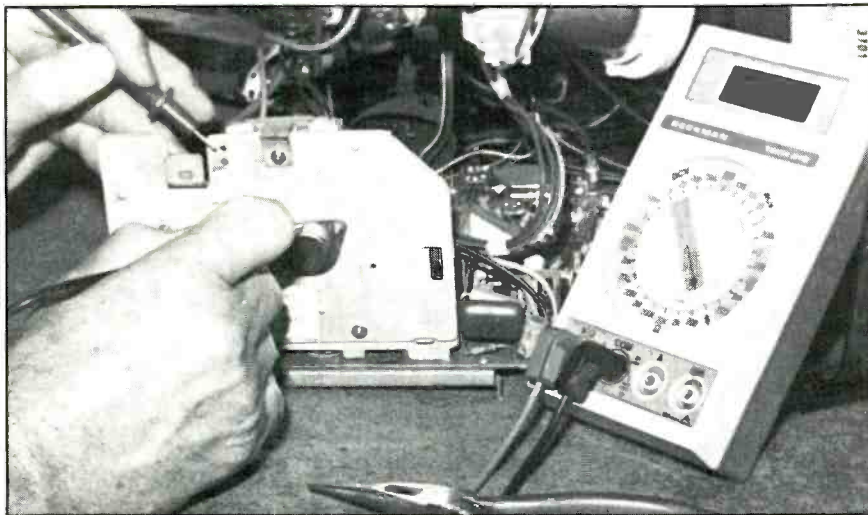

In a CT-330M Samsung portable, leakage of the STR-382 voltage regulator was located with a DMM's diode-junction test. Replacement of the defective regulator with a STR-382 original part number IC completed the repair.

voltage should be high (+135V to +155V) compared to the regulated output voltage. Zero dc voltage might indicate an open in the fuse, ac on/off switch or voltage-dropping resistor. If the TV is operated with remote control, use a short test lead to connect across the relay switch contacts.

A low dc-voltage reading at the collector terminal of the horizontal-output transistor or at the output of the IC regulator can result from a defective power supply or from a good power supply with overload. When the voltage is low after the horizontal-output transistor has been removed, suspect the power supply. However, do not overlook the small

possibility that a shorted audio-output IC or transistor in the sound circuits also can reduce the power-supply voltage. Both sound and horizontal-output circuits are supplied with the full voltage from the IC low-voltage regulator.

Overloads

The regulator IC, fuse, 120Vac diode rectifier and isolation resistors can suffer damage from a shorted or leaky horizontal-output transistor. A faulty damper diode, which in many portable TV chassis is placed inside the horizontal-output transistor, may also damage these components. Without proper drive voltage to the horizontal-output transistor,

SAVE BUY DIRECT

15-DAY FREE TRIAL

LTC-5 **\$254.95**
Logic Analysis Test Kit

- 100 MHz frequency response
- 5 ns pulse train
- Case included

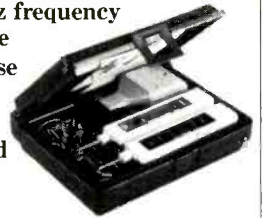

Our completely portable LTC-5 test kit is circuit-powered and features our new ultra-fast LP-5 logic probe. Capable of capturing pulses at 5 ns and pulse trains at 100 MHz, you'd expect to pay more than our incredibly low catalog price of only \$254.95. Our new catalog also offers a large selection of electronics testing and prototyping equipment at low direct-from-the-factory prices... proving you really can buy the *best for less!*

Call TOLL-FREE
1-800-345-6251
(1-800-445-6250 in Connecticut)

To order your LTC-5 at our low catalog price simply call our toll-free order line, mention this ad and have your Visa or MasterCard ready. Or send your check with the coupon below.

There's a lot in our new catalog that will interest you. Send the coupon below and we'll put you on our mailing list.

FREE Catalog

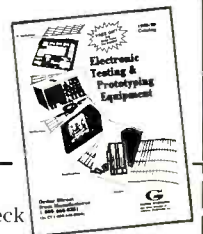

- Enclosed is my check for the LTC-5.
(CT and CA residents include state sales tax.)
- Please send me your new Global Direct Catalog.

Name _____

Company _____

Address _____

City _____

State _____

Zip _____



EST-11/88

Global Specialties
Mail Order Division
P.O. Box 1405
New Haven, CT 06505

Circle (15) on Reply Card

Repairing lightning damage

After lightning has jumped around inside a Goldstar NC-05X3 chassis, the damage might consist merely of a blown power-line fuse and IC801 IC regulator. In other less fortunate cases, IC801, R₈₀₃, R₈₀₁, D₈₀₁, F₈₁₂ and a horizontal-output transistor require replacement.

After you replace all the damaged components, do not operate the receiver with the full 120Vac. There might be overloads that do not become apparent until power is applied, and it is not possible to examine and test all smaller components of the regulator circuits following lightning damage. Therefore, the receiver should be operated with low line voltage until it's safe to increase the ac line voltage to normal. The range of a variable-voltage transformer is typically from zero to about 130Vac, so the voltage should be checked by meter.

In addition to the variable-voltage transformer, connect a voltmeter to monitor the voltage at the output terminal of the IC regulator. Clip the test probe of a scope to the base terminal of the hori-

zontal-output transistor. Start with the artificial line voltage at about 40Vac. If there is no heating or overload, slowly bring the ac voltage up to 65Vac or 70Vac and recheck the regulator's output dc voltage. Does the scope show any (even weak or distorted) drive waveform? "No" indicates a problem. Remove fuse F₈₀₂ and connect a current meter across the terminals. Excessive current indicates either a defective regulator or a regulator load, such as the horizontal-output circuit.

Disconnect the flyback wire at the collector terminal of the horizontal-output transistor, then slowly increase the line voltage to the TV. When the regulator is normal, the output voltage should rise as the ac voltage is increased. If the voltage at the regulator IC remains low, however, suspect a leaky regulator or corresponding component. When the horizontal circuits are defective, check the waveform at the horizontal countdown IC and driver transistor.

Proper use of the variable-voltage iso-

lation transformer can prevent damage to the newly replaced IC regulator.

In another case, a Samsung CT330M portable was brought in from a farm where it had been damaged by lightning. After I replaced the fuse, the line-voltage diode and the isolation resistors, I found that the IC voltage regulator was leaky. That judgement of the IC was not made lightly, but after accurate resistance and voltage measurements were made on the STR-382 regulator.

Before replacing the suspected regulator, I connected the variable-voltage transformer. As the ac voltage was increased from 40Vac, the abnormally small dcV reading increased slightly and then leveled. The transformer groaned and the fuse blew when 87Vac was applied.

Replacement of the STR-382 IC regulator with the original part number regulator solved the low +125V-supply problem.

the fuse might continue blowing. (In the complete absence of drive, the output transistor usually draws no current and causes no damage. However, off-frequency erratic pulses from the horizontal driver should be avoided; they can cause damage.) Overloaded circuits that take energy from the flyback's secondary windings can reduce the dc voltages at the IC regulator.

Determine if the horizontal circuits have a defect by removing the horizontal-output transistor or the B+ supply-voltage wire from the flyback. If the dc voltage is still low at the IC-regulator output, suspect a leaking IC regulator or leakage in the sound circuits. Temporarily disconnect the sound circuits' B+ source at the regulator. (The method depends on the individual model, and it will vary. Use Yankee ingenuity.) An increase of regulator output when the sound circuits are disconnected proves that the sound circuits are drawing excessive current.

An open or leaky IC regulator might produce either lower or higher than normal B+ voltage at the output terminal. One reason for a partial B+ voltage at the output when the IC is open is a large-wattage resistor that often parallels the regulator. (See Figure 6.) This re-

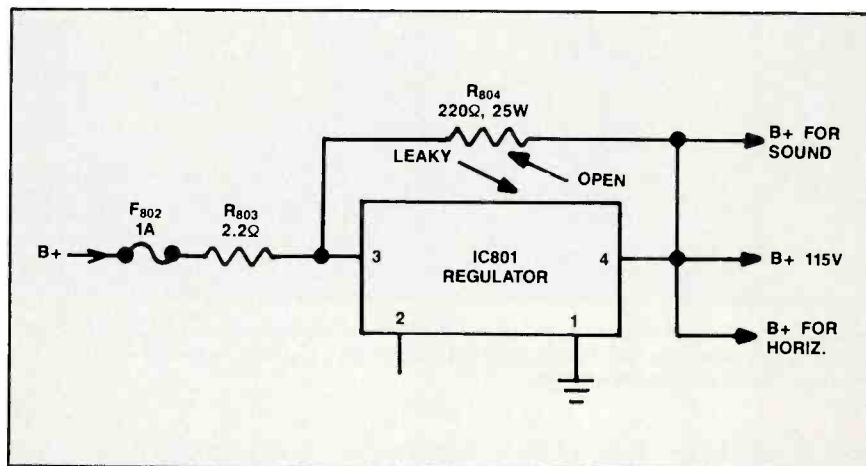

Figure 6. R₈₀₄ seems to be superfluous because it parallels the emitter/collector path of IC801. However, R₈₀₄ shares the current and thus reduces the heat in IC801. Keep in mind that this and similar circuits regulate by varying a resistance between the voltage source (collector or equivalent) and the load (emitter or equivalent). IC801 varies its internal resistance between terminals 3 and 4, and that adjusts the output voltage. If R₈₀₄ develops reduced resistance, the B+ rises and the IC801 regulator action decreases. With the higher B+ comes high-voltage arcs and other horizontal problems. If R₈₀₄ opens, IC801 is forced to pass all the load current, possibly bringing the IC above its safe temperature and causing an early failure of IC801. If IC801 is open, R₈₀₄ alone will pass enough current to produce a low B+ output voltage, but the resistor is very hot, and the TV does not operate.

sistor shares part of the current with the regulator; therefore, the regulator can operate at a lower temperature. When the input dc voltage is normal but the IC dcV output is very low or otherwise incorrect, the suspect is the regulator

IC. Replacement usually is the only reliable test for these regulator ICs. If the performance is no better, the IC was not defective; if the operation becomes normal, the IC positively was defective.

ES&T

Editor's note: Periodically, ES&T features books dealing with subjects of interest to our readers. Please direct inquiries and orders to the publishers at the addresses given.

**Application Notes Digest;
D.A.T.A. Business Publishing;
annual subscription: \$60.**

This 33rd edition presents more than 5,270 application notes available from manufacturers of integrated circuits and discrete semiconductors. The notes cover linear, digital, memory, micro-processor and interface ICs; diodes; thyristors; optoelectronic components; transistors; and power semiconductors. The digest also includes application and category cross-references and a manufacturer directory.

D.A.T.A. Business Publishing, 9889 Willow Creek Road, P.O. Box 26875, San Diego, CA 92126; 800-447-4666 (800-854-7030, ext. 570 in California).

**VCR Model Cross-Reference and
Parts Cross-Reference; IS CET;**

**256 pages; \$30 (add \$3 postage
and handling).**

The book, published by the International Society of Certified Electronics Technicians and the Arizona State Electronics Association, allows technicians to cross-reference schematics and parts. Brands covered include Panasonic, Quasar, GE, Magnavox, Philco, Canon, Sylvania, Curtis Mathes, JC Penney and RCA. Updates will be available semi-annually.

IS CET, 2708 W. Berry St., Fort Worth, TX 76109; 817-921-9101.

PHOTOFACT

MAGNAVOX

2612-1CH3930AL/AL02/
BL/BL02/DR/DR02/RD/RD02

PANASONIC

2607-1CTJ-2770R/81R/82R/87R
2608-1CTJ-2561R/67R,
PC-26P61R/67R/68R
2611-1CTJ-2551R/57R,
PC-26P51R/57R

2613-1CTJ-2062R,
CTJ-2062R-1

RCA

2608-2CHASSIS CTC140B/C/E,
CTC140AC/AE

SANYO

2609-191C622
(CH. A8D-62200/01)
2613-2 ...AVM220 (CH.A8L-22000)

SEARS

2607-2564.42311750/51/52
2609-2564.40453750/51
2610-1564.42452750/51

SHARP

2612-225LC156

ZENITH

2610-2SC2705G/09P/11N/13H/
15A/19P/87P/89H/99S, SC5755P
2611-2C2568W, SC2513G/15N/
17P/69W/69X/85P/91S/93L/
93W/93Y, SC5593S/97Y



SPECIAL REPORT

SPECIAL REPORT

SPECIAL REPORT

SPECIAL REPORT

SPECIAL REPORT

SPECIAL REPORT

SPECIAL REPORT

SPECIAL REPORT

SPECIAL REPORT

SPECIAL REPORT

SPECIAL REPORT

SPECIAL REPORT

SPECIAL REPORT

SPECIAL REPORT

VCR SERVICING

All you need to know about servicing personal computers is in this exclusive report coming in January, 1989 in:

ELECTRONIC
Servicing & Technology

Uninterruptible power systems

The Onguard PC-1240 and the PC-2400 non-linear uninterruptible power systems from *Clary* offer RS-323 signal-level interfaces, high-frequency PWM converter/inverters and low-impedance filtering systems. The PC-1240 provides 5 to 15 minutes of on-line, sine-wave backup for two typical IBM ATs or compatibles. The 750VA PC-2400 offers 12 to 24 minutes of on-line, sine-wave back-up power for up to three LAN file servers. Both units provide 480VA of filtered power for secondary loads; peak repetitive current for UPS loads is 15A for the PC-2400, 7A for the PC-1240. Both units also feature pulse-width modulation and can sustain power indefinitely during a brownout.

Circle (74) on Reply Card

Computer diagnostics

Jensen Tools has introduced the PC-Technician, a diskette-based, full-system diagnostics program that is available in both PC/XT and PC/AT configurations. The program reads system configuration switches and displays their setting. Functions include memory diagnostics for uncovering bad memory chips and maximum stress testing on floppy and fixed disks.

Circle (75) on Reply Card

Portable DSO

Tektronix has introduced the 2201 portable digital storage oscilloscope (DSO), which features a 10MS/s sampling rate, pretrigger, 8-bit resolution, 1MHz useful storage bandwidth and 2K

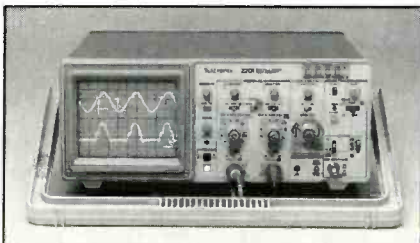

record length. The scope also provides a 20MHz bandwidth, dual channels and sensitivity from 5mV to 5V per division. An optional serial interface supplies hardcopy capabilities.

Circle (76) on Reply Card

Digital multimeters

Three digital multimeters, types DM-51, DM-53 and DM-55L, have been introduced by *Philips ECG*. Type DM-51 provides eight functions and 21

ranges and has 200M Ω full scale. Type DM-53 has nine functions and 30 ranges including capacitance and has 20M Ω full scale. Type DM-55L has 10 functions, 30 ranges, a logic detector and a frequency counter. Each RF shielded unit features a 3½-digit LCD display with ½-inch high characters, a polarity indicator, 0.5% basic dc accuracy, an audible continuity test, a diode test, a transistor hFE test and 10A dc.

Circle (77) on Reply Card

Cable test kit

The Cable Sender/Tracer Kit, introduced by *MicroTest*, makes it possible to detect breaks in wiring and pinpoint the location of any cable hidden from view. The Cable Sender injects into the wiring a 2-tone signal that the Tracer can detect.

Circle (78) on Reply Card

Electrolytic capacitors

NTE Electronics has announced its standard and high-voltage electrolytic capacitors. Voltage values range from 6.3V to 450V with capacitance ranging from 0.10 μ F to 10,000 μ F. All values are available in either axial or radial lead versions.

Circle (79) on Reply Card

Digital multimeters

The models 2833 and 2832 bench-style DMMs have been introduced by *B&K-Precision*. The model 2833, a 4½-digit true rms meter, measures frequency up to 200kHz and dBm from -48dB to 62.21dB. The model 2832, a 3½-digit multimeter/capacitance meter, measures capacitance to 20F. Both models measure current to 20A and feature a basic dcV accuracy of 0.05%, LCD readouts, push-button operation and an audible continuity checker.

Circle (80) on Reply Card

Transmission test set

Triplett's model 7 transmission test set is a water-resistant transmission-line tester combined with a multimeter. The set will test circuit loss (accuracy of ± 0.2 dB), circuit noise (accuracy of ± 0.2 dB at 1,000Hz), power influence (accuracy of ± 0.4 dB at 1,000Hz), line current (accuracy of ± 2.0 %) and ground current (accuracy of ± 2.0 %). The ohmmeter ranges are 15Vdc, 60Vdc and 300Vdc; 60Vac and 300Vac; and 10 Ω , 10k Ω and 100k Ω center scale. The

set features an analog display and is self-compensating for 600 Ω /900 Ω input.

Circle (81) on Reply Card

Circuit refrigerant

Chemtronics' E-Series Freez-It is an environmentally safe circuit refrigerant that will instantly freeze small areas to as low as -96°F and will quickly evaporate, leaving no residue. The refrigerant



ant provides both high purity and low toxicity and inertness. The product is a second-generation EPA exempt fluorocarbon and has been designated as a substitute for regulated CFCs.

Circle (82) on Reply Card

Logic analyzer

The PLA-3300 from *Primeline* is a portable, 16-channel logic analyzer with an LCD display and state, timing and signature analysis functions. The analyzer features a 10MHz clock rate, 100ns resolution, 15ns glitch detection, 256 bits/channel each of reference and acquisition memory plus setup data and a GRIB interface. Data recording can be triggered on words, glitch detection or clock delay.

Circle (83) on Reply Card

Surge protector

The CoaxMAX SSP surge protector from *Panamax* has an extended frequency range of 4GHz to protect satellite TV receivers from lightning surges. Stage one offers a 27V clamping level, a 5 picosecond response time and a 4,500W 100 μ s power dissipation. Stage two offers a 25V clamping level, a 10ns response time and a 110,000W 100 μ s power dissipation.

Circle (84) on Reply Card

Coaxial wire stripper

The Coax Stripmaster wire stripper from *Ideal* has a 2-hole blade to strip coaxial wire. The large hole removes the

outer jacket; the smaller hole cuts through dielectric material. Features include 1-step, spring-action operation and cushioned plastic hand grips. A wire stop is optional.

Circle (85) on Reply Card

Multimeter accessory

The 80i-kW current/power probe from *John Fluke Mfg.* is a clamp-on multimeter accessory that measures dc current, ac current and ac power in kilowatts. The probe has a measurement range of 1A to 1,300A dc, 1A to 1,000A ac, and 0.5kW to 330kW. The switch-selectable output signal is 1mV per amp or 1mV per kilowatt.

Circle (87) on Reply Card

Copper desoldering braid

Kwik-Wik copper desoldering braid, introduced by *M.M. Newman*, is flux-impregnated to absorb solder by capillary action. It is available in 0.03-, 0.06-, 0.08- and 0.10-inch sizes on 5-foot spools.

Circle (88) on Reply Card

Wire stripper

Paladin has introduced the PA 1101 Maxi-Stripax, a fiberglass wire stripper with 66 stainless steel stripping blades that can strip and cut 10- to 22-gauge wire, flexible and solid PVC, multi-core ribbon cables, hard PVC insulation, and



double-insulated or fiber-optic cable. The product features a built-in wire

stop, insulation to 600V, front feed and a built-in wire cutter.

Circle (89) on Reply Card

Portable soldering iron

HMC has introduced the model B700 butane-powered, portable soldering iron, which comes with a built-in igniter, heats in less than 30 seconds and offers temperatures equivalent to conventional 10W to 60W irons. The static-free iron has no open flame (each replaceable soldering tip comes with a catalytic converter) and cools in seconds.

Circle (90) on Reply Card

Transient-voltage surge suppressors

POWERMEDIC transient-voltage surge suppressors, introduced by *Deltron*, feature an audible alarm, a suppressor indicator light and an illuminated master switch. The product has a 350J capacity and is available in 4- and 6-outlet versions.

Circle (91) on Reply Card

ES&T

Come Out of the Dark.

If you're searching for the perfect way to illuminate your business, make the switch to the NESDA Form, a universal billing form for COD or warranty work accepted by all major manufacturers. It's only *one* of many "enlightening" benefits offered to members of NESDA. For more information about NESDA, and a sample of the NESDA Form, just mail the following to NESDA:

Name _____
 Address _____
 City _____ State _____
 Zip _____
 Phone _____

National Electronics Sales & Service Dealers Association
NESDA
 Service Dealers Association

2708 W. Berry St.
 Ft. Worth TX 76109
 (817) 921-9061

One of a series.

DON'T LET THIS HAPPEN TO YOU!

Before *After*

I Was A Wreck Until I Started Ordering My Parts From The MCM Electronics Catalog!

Since I made the switch to MCM Electronics, I can choose from their huge assortment of over 11,000 products. If I have a question about a particular item, I can call and get the answer. If I need something fast, I can get it — when I need it! And the best part of all is that everything I've ordered has performed as promised...with no exceptions! I couldn't ask for anything more. And neither could you! Make your switch to MCM — TODAY!

For your **FREE** copy of our all-new MCM Electronics Catalog...
CALL TOLL-FREE 1-800-543-4330
 ...or write...

MCM ELECTRONICS
 858 E. CONGRESS PARK DR.
 CENTERVILLE, OH 45459-4072
 A PREMIER Company

Source No. ES-39

Circle (16) on Reply Card

Servicing the compact disc player—Part II

By Martin Clifford

This is the second part in a series on servicing compact disc players. Part I dealt with narrowing down the possible causes of the trouble symptoms. Part II will describe subjective and objective testing.

A CD player can be tested subjectively or objectively. A subjective test is a listening test—the ears of the auditor are the means of evaluation. An objective test is one made with instruments.

Subjective tests can be made in three ways: You can listen to the sound output of a player, possibly using a disc that has been played repeatedly and so is very familiar; you can use a test disc; or you can use an A/B type test using a pair of CD players with one of these as a known standard in good working order.

Tests of this kind can be useful for determining faults that are fairly obvious. How useful they are depends on the auditor's age, sex, musical background and the frequency response of the listener's ears. Although a compact disc can have a response from 20Hz to 20kHz and a frequency response deviation of $\pm 0.5\text{dB}$, few if any of us have such a hearing range. It is also doubtful that the human ear and brain can be conscious of a frequency deviation of only 0.5dB.

CD test records

There are two types of CD test discs. The first, intended for subjective evaluation tests, supplies musical tones and indicates their frequencies. The test record may also have short musical passages as a check on dynamic range, supplying some that are very quiet followed by peak audio signals, possibly those of percussion instruments.

The other type of test disc is for use

with various test instruments such as a distortion analyzer, a harmonic analyzer, a signal-level meter and a scope. Some of these may be separate units or may be integrated.

There are a number of commercial test discs available. These include the Sony YEDS-2 and YEDS-7, Philips 410/055-2 and 410/056-2, and the Denon DNC39-7147 and DN-3000F.

The purpose of a test disc is to simulate faults to challenge the response of circuitry in compact disc players, specifically the laser optical-tracking and error-correction systems. The disc flaws do not have the same levels of severity, and when using a test disc, you must determine just how the flaws can be rated.

A test disc can also include left- and right-channel signals having a range from 20Hz to 20kHz. Instead of having a complete audio sweep, some test discs supply 10 spot audio frequencies. A test disc could also have spot frequency signals at 1kHz, 5kHz and 16kHz as a test of the de-emphasis network's ability to respond.

A disc could also have specific frequencies for checking not only left- and right-channel sound separation but channel balance as well. Thus, a test disc not only checks the response of error and tracking circuits, but it can also be used as a way to verify a manufacturer's specifications and on-circuit performance.

Discs are also used to check the audio performance of a CD player, including distortion measurements. A disc may contain a 0dB reference tone for measuring signal-to-noise ratios because 0dB represents the peak signal level that is recorded on compact discs.

Test discs have deliberately introduced faults that could be contained in a compact disc not properly cared for as a means of determining how well the CD player can overcome them.

These test discs contain wedges consisting of a series of opaque black dots. The dots are not the same size and gradually increase in diameter. They are meant to represent scratches and specks of dust of different sizes. Because compact discs are also subject to fingerprints, test discs may contain a partially opaque smudge where fingerprints are usually most prevalent, near the edge of the disc. The black dots vary in width from 400 to 900 microns (micrometers or millionths of a meter) and are used to represent a scratch. Dots that measure from 300 to 800 microns simulate a scratch or possibly a fingerprint.

One advantage of a test disc is that it can be used to simplify the A/B testing of CD players. Assuming a compact disc is in perfect condition, even a low-end player can produce good results. However, top-quality players are much more able to take defects on discs in stride. In time and with continued use, compact discs can suffer the onslaught of dust, dirt, fingerprints and scratches. A low-end player will evidence the results of these defects; a top-quality player will handle these discs as though they were taken out of their jewel box for the first time.

CD player problems

Some compact disc player problems are so elementary that solving them might seem almost automatic and yet can cause concern at the time they occur.

If the CD player doesn't work, it is entirely possible for one outlet to lose power because power lines in the home are subdivided into branches, each with its own fuse. Plug in a lamp or use a neon-bulb outlet tester to check whether the outlet being used by the CD player is live.

Make sure the power switch is turned on. Some users think inserting the disc

Clifford, a freelance writer, has published more than 75 books on electronics.

into the player turns the power on automatically. Players generally have a glow lamp to indicate that power is being received. If the outlet tests live, wiggle the male plug of the player in the outlet. If this restores power, simply bend the blades of the plug slightly outward to improve outlet contact.

If the player is being installed for the first time, check to make sure it is meeting its power input requirements. Some players have a switch to permit the unit to be operated by different line voltages. Check the switch (Figure 1) to make sure it is set to its correct position for the line voltage in your area.

For the United States and Canada, that voltage should be 120Vac. For other countries it is variously 220V, 240V, 50Hz and 60Hz. Some CD players are multipower switchable and can accommodate 110V/120V/220V/240V, 50Hz/60Hz. Always check the voltage selector before connecting the CD player and turning it on. On some players, the variable-input voltage control is

screwdriver-adjustable.

Make sure the disc drawer is operative. Even if power is being supplied to the player, it will not function until the disc drawer works correctly. Also check to make sure the disc has been inserted properly. If the disc is loaded upside down, the player will not work. The disc must be loaded with its label side up.

If the unit is a battery-operated portable, slide open the battery compartment and replace the batteries. The player will be using two or more of them. Don't try to economize by using just one new battery, even if just one does solve the non-operating condition. Be sure to put in all new batteries.

A CD player will not function unless a CD has been inserted and is in position. You may think you have left a CD in its drawer, but in case of non-operation, check to make sure. Sometimes, just as is the case with VCRs, the formation of moisture inside the CD player will keep it from play-

VOLTAGE
SELECTOR

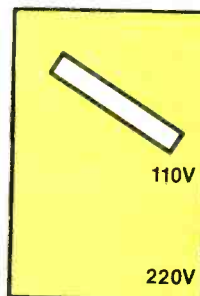

Figure 1. If the player is being installed for the first time, check to make sure it is meeting its power input requirements. Some players have a switch to permit the unit to be operated by different line voltages. Check the switch to make sure it is set to its correct position for the line voltage in your area.

ing. Don't try to warm the player by putting it closer to a heat source. Keep it at room temperature for at least a half hour and then try again.

Some players won't operate if the pause button has been depressed twice. Push the pause button once again to see if this will restore operation. **ES&T**

Learn how to repair VCRs...

Read

Video Corner

each month
in **ELECTRONIC**
Servicing & Technology



Plug in!

To the NESDA system.

YOUR BUSINESS is in the world's fastest changing industry. If you're not careful, you could find your business in the dark.

But, you don't have to stay there.

Through a system of local, state, and regional groups, the National Electronics Sales & Service Dealers Assn. (NESDA) keeps members up-to-date with the fast pace of advancing technology while offering:

- ◆ Managerial and technical training.
- ◆ Business contacts.
- ◆ Technical and management certification.
- ◆ Information on new products.
- ◆ Legislative activities that affect the industry.

Don't be left in the dark. Let the NESDA system work FOR YOU!

For more information and an application, write to:
NESDA, 2708 W. Berry St., Ft. Worth, TX 76109; Ph (817) 921-9061

Name _____

Bus. Name _____

Address _____

State _____ Zip _____ Phone _____

Member of State Local Assn. _____

Noise in the picture on playback

One of the common problem symptoms in a VCR is noise in the picture. Depending on the particular kind of noise and what part of the picture it's located at, the problem could be caused by tape dropouts, a misadjusted tape path, video-head problems, control-system problems or a number of other electronic or mechanical problems. Diagnosis of the problem consists of closely observing exactly what the symptoms are and taking a close look at the block diagrams, the schematic diagrams and the physical appearance of the VCR itself to form a logical prediction of where the problem is coming from.

In one VCR, for example, the symptom was noise that traveled through the picture, then a stable picture appeared

for a while, followed by another area of noise traveling through the picture. In this particular case, the video noise was accompanied by an absence of sound.

One of the causes of this type of video noise is a video head that is tracking in the guardband between video tracks instead of right on a video track. The video symptom points to a problem either in the video-head circuitry or the capstan circuitry. The symptom of sound problems as well narrows the problem down: The problem is affecting both tape speed and audio. The place where both video control and audio come together is at the audio/control head.

In this particular case, the oscilloscope was used to observe the output of

both the control head and the audio head. Neither waveform was present. Investigation revealed that, in this case, the problem was a disconnected plug between the audio/control head. Rather than a complete loss of audio, you might see less severe problems of a similar nature, such as noise wandering through the picture accompanied by audio distortion, which might be caused by a misadjusted or dirty audio/control head.

Keep in mind that in high-fidelity-audio VCRs, this problem might be a little less obvious. Even though the linear audio head might be putting out no sound or distorted sound, high-fidelity audio recorded along with the video on helical tracks may be putting out good sound. If you suspect a control/audio problem, it might help to confirm linear audio problems by playing a tape that you know doesn't have high-fidelity audio recorded on it.

Tracking control

Proper playback tracking requires that both the phase (position) and the speed of the video heads across the tape be

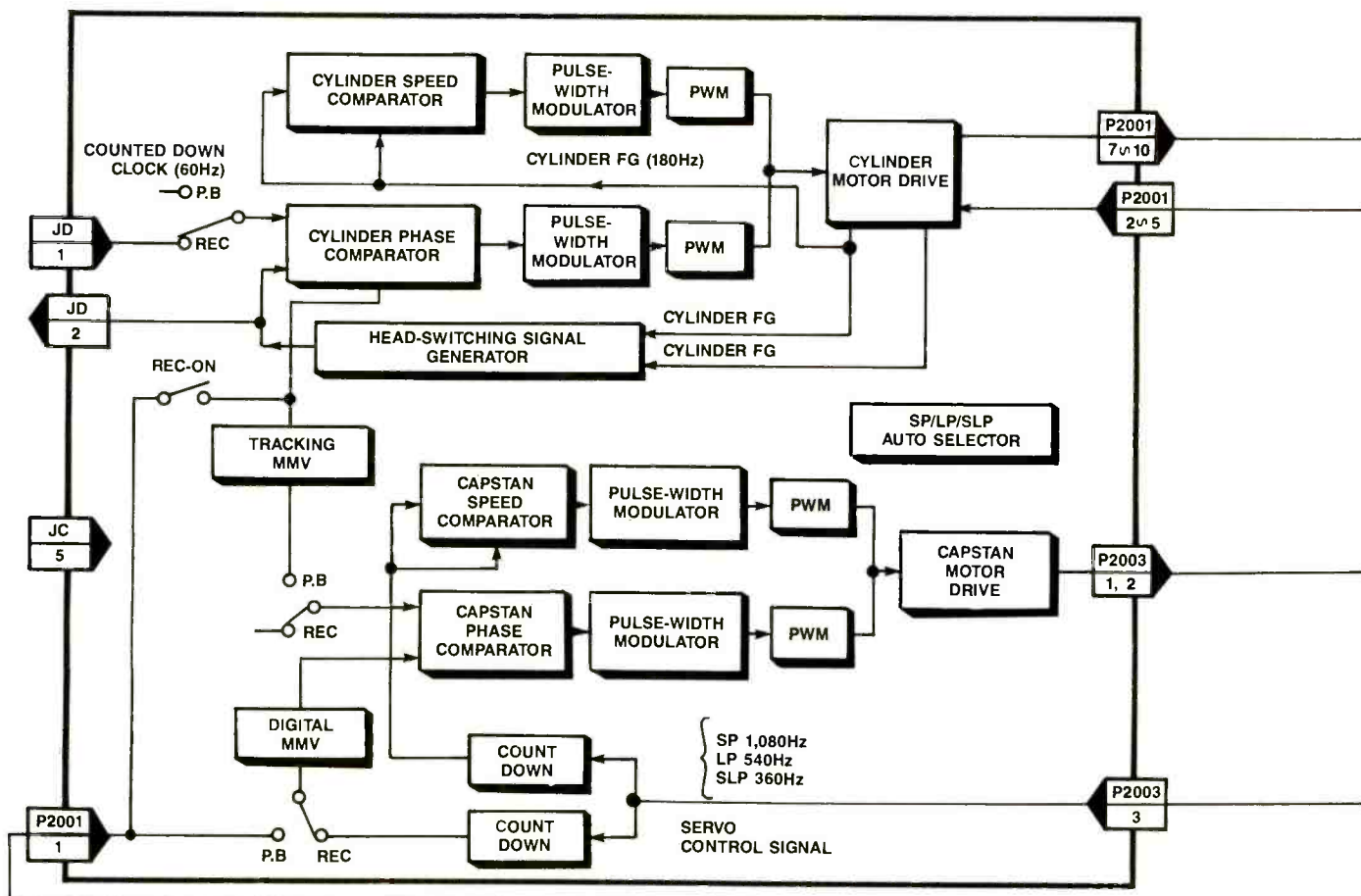

correct. The speed at which the tape is fed past the heads must also be correct, so signals recorded on the tape during record are fed to the capstan along with video-head speed and position information during playback to keep the video heads tracking accurately over the video tracks.

The reference for the capstan servo is the vertical sync from the NTSC waveform. During record, this signal is sent to a sync separator that wipes out all of the video information and everything else that is not sync. The sync information is then used to generate a 30Hz pulse that is recorded on the control track of the tape.

Here's some more detail on how the capstan motor and the head cylinder motor are coordinated to maintain proper tracking. In the playback mode, the capstan motor should be controlled so that the video heads trace the proper tracks. In order to keep the proper relationship between the cylinder and cap-

stan servo, the reference signal is produced from the signal coming from the cylinder phase control. The 60% duty rectangular pulse from the cylinder servo is applied to the playback tracking monostable multivibrator as the trigger pulse. The MMV output is fed back to produce a trapezoidal waveform. The TRACKING control on the VCR's front panel adjusts the time constant of the MV, adjusting the phase relationship between the cylinder and capstan motors. The capstan phase comparator maintains synchronization between the reference signal and the control track signal.

Tracking problems such as this may be caused by a number of problems in the tape path or in the drive electronics. Arriving at a diagnosis requires that you carefully observe the symptom, trace the signal through the control system, and recognize the cause of the problem when you encounter it.

ES&T

D.D. CYLINDER

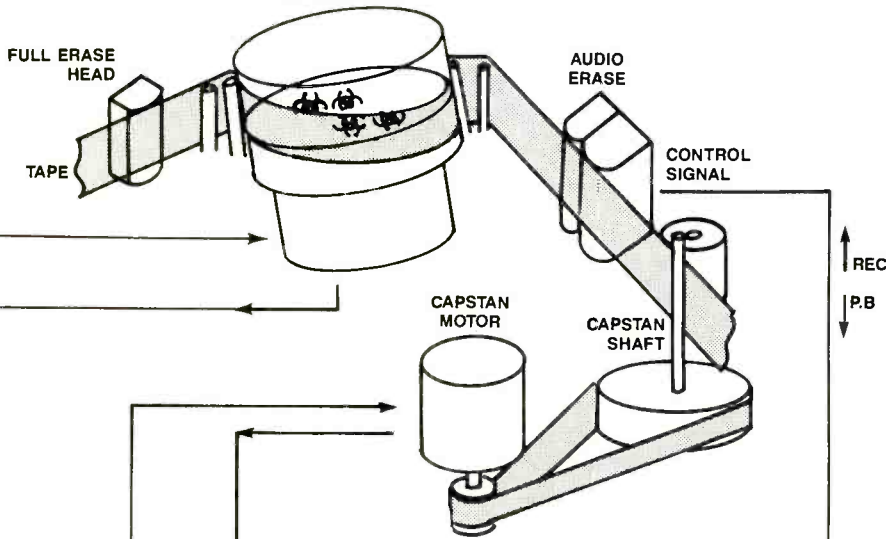

Figure 1. Noise that travels through the playback picture may be caused by a dirty, mis-adjusted or disconnected control head. In this particular case, absence of a linear audio signal isolated the problem to audio/control. (Block diagram courtesy Thomson Consumer Electronics.)

**Technicians,
Get Serious
About Your
Profession**



Being a certified electronics technician lets people know that you are a professional in your field. It tells them that you are serious about your work and can perform up to CET standards.

Now you can order the "Study Guide for the Associate-Level CET Test" from the International Society of Certified Electronics Technicians. It includes material covering the most often missed questions on the Associate CET exam. 8 1/2" x 11", paperback, 60 pages.

For More Information Contact:

IS CET, 2708 W. Berry, Fort Worth, TX 76109; (817) 921-9101

NAME _____
 ADDRESS _____
 CITY _____ STATE _____
 ZIP _____
 _____ copies @ \$5 (+ \$1 postage.)
 _____ send material about IS CET and becoming certified.

CONSOLIDATED
ELECTRONICS

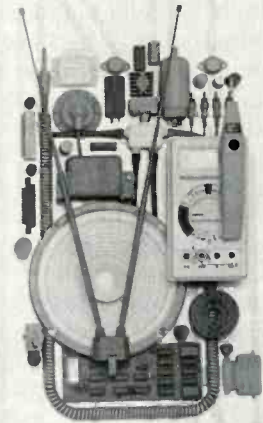

CONSUMER & INDUSTRIAL ELECTRONICS CATALOG • 17TH EDITION

**THE ULTIMATE
ELECTRONICS CATALOG.**

Order your 260 page catalogue packed with over 10,000 money saving electronic parts and equipment. Send \$3.00 check or money order, or call 1-800-543-3568 today and use your Mastercard or Visa.
 Consolidated Electronics, Incorporated
 705 Watervliet Ave., Dayton, Ohio 45420-2599

NAME _____
 ADDRESS _____
 CITY _____
 STATE _____ ZIP _____

Circle (18) on Reply Card

Elements of video optics

—Part IV

By Carl Bentz

This material was adapted from "TV Camera Optics," published in Broadcast Engineering, August 1986. Information for this article was provided by Angenieux, Canon, Fujinon, Schneider and Tamron.

Although the lens portion of the optical chain is designed to reduce separation of light into colors, the final section must efficiently split the beam into red, green and blue. Most early color cameras used front-surface dichroic mirrors to perform the separation. Dichroics involve thin layers of material that can discriminate between colors of light, allowing one to pass through while causing another to be reflected.

As with all other elements in the optical path, the index of refraction of dichroic coatings is the secret to their effects. The thickness of the dichroic layers is only a fraction of the wavelength of the color to be affected. With layers plated onto the front surface of a mirror, green and red are transmitted while blue is reflected. (See Figure 1.) A second dichroic passes red and reflects green. In each case, trim filters precisely define the wavelength of light that reaches the camera tube.

Dichroic mirrors are effective in color separation and allow all three tubes (or, in early camera designs, four tubes) to be in parallel. Today, more efficient splitters use prisms, although the tubes can no longer lie in a convenient side-by-side configuration. Careful selection of indices of refraction, placement and shapes causes one or more prisms to split the light into red, green and blue components, again, with trim filters to achieve high color accuracy.

The right lens for the job

Selecting a TV lens involves several factors. The lens must match the camera. Some literature refers to the optical format by tube diameters. More accu-

rately, however, the format indicates the diagonal of the scanned area on the camera-tube faceplate. A 1/2-inch tube generally provides a diagonal measurement of 11mm.

Only a fourth of the image produced by a 1-inch lens would fall on the faceplate of a 1/2-inch tube. A 2/3-inch lens would leave a portion of the 1-inch tube unexposed. The relay group at the rear of the lens matches the required size. Some cameras, designed to use more than one size of camera tube at the same time, must have elements in the optical block to achieve the correct format for each tube.

The back focal length of the lens must match the camera design. Some adjustment is normally available on lenses, but the amount of adjustment is to compensate manufacturing tolerances. For best results in specifying a lens, mention the camera model on which it will be used.

Maintenance

In most cases, the greatest maintenance requirement of the lens system is cleaning the outside housing and the glass surfaces. The front element, which is exposed to the elements, may collect dust or become spattered with water. Dust should be removed with a light touch from a soft, lintless cloth. An even better cleaner is a small can of compressed air. Whenever possible, avoid touching the glass surface of the lens.

Carefully remove smears on the glass with a detergent solution. Avoid exotic cleaning solutions. For unusual situations, contact the lens manufacturer. Once the lens is clean, it might be a good idea to install a clear glass cover over the front element. The cover ensures protection for the lens at a minimal cost.

The rear lens surface and any optical elements inside the camera also must be kept free of dust because particles on those surfaces may appear in focus. Again, a soft cloth or brush and the can of air are preferred methods of cleaning. If the system includes front-surface mirrors, never rub the surface to remove dirt or smears. Use soft brushes or air.

The movable elements of a zoom lens are usually enclosed in a partially sealed environment. In theory, dirt should not get into that environment. If it does, consider sending the lens to the manufacturer for servicing. Glassware elements in zoom lens systems are best considered non-user-serviceable parts and are best left to qualified optical specialists.

If you have found it necessary to remove the lens housing, you may want to check the operating manual in regard to lubricating the moving parts. The environment in which a lens is used may require a different lubricant than the manufacturer originally used. If that is the case, use only the manufacturer-

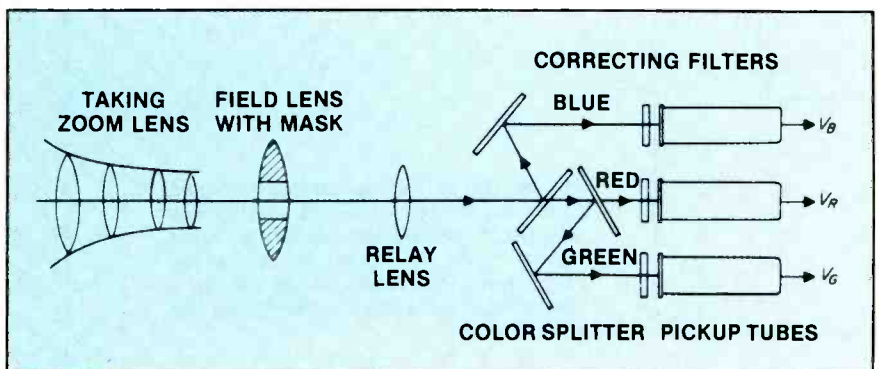

Figure 1. Dichroic mirrors may be used to separate a full color image into red, green and blue images for the pickup tubes.

Bentz is the TV technical editor for *Broadcast Engineering* magazine.

Lens types

There are six primary lens types, based upon shape. The most common is the *double-convex lens*, which has the greatest light-converging power. Parallel light rays passing through the element are forced to converge at a point that is related to the focal length of the lens.

If one side of the lens is flat, the element is *plano-convex*. For the same convex curvature, the lens has only half the converging power of the double convex type.

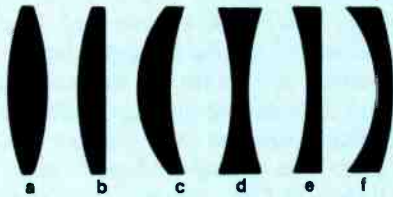

Six primary lens types are used in TV optics: (a) double-convex; (b) plano-convex; (c) convex meniscus; (d) double-concave; (e) plano-concave; and (f) concave meniscus.

Also considered a converging lens is one type of *meniscus* lens. Although the back side is concavely shaped, the radius of curvature is less than the front surface. As a result, light rays are converged, but the focal distance is greater than either the double- or plano-convex unit. The meniscus is the weakest type.

Diverging lens elements are commonly associated with the concave shape. As with convex, the *double-concave* element has the greatest power to change the image. Such lenses do form an image, but the virtual image appears to be on the same side of the lens as the object.

The *plano-concave* lens has only half the diverging capability but otherwise retains the characteristics of the double lens. Such elements provide optical corrections in the lens system.

A concave meniscus lens also exists. Again, the back side of the lens is curved, this time with a convex shape. The convex curvature is less than that of the concave side. Parallel rays passed through the lens do not converge.

specified oils or greases, sparingly.

Adjustments may be needed for integral pattern projectors found in some systems. Access to these adjustments has been simplified by designs with housings that can be removed without unmounting the lens from the camera. In others, access doors make available only the areas for adjustment and keep other areas protected.

The TV camera optical system, more than any other assembly of the camera chain, requires a thorough understanding by the maintenance technician. Unwarranted disassembly can result in greater problems than existed in the first place. If there is any question on the best approach to a problem, contact the manufacturer for advice.

TV camera optical systems are among the most sophisticated devices. As in any maintenance project, do not try to fix something that is not broken. Because of critical alignments involved with the optics, focus on the real problems, then proceed with care. **ES&T**

WATCH FOR

BUSINESS CORNER

coming in January, 1989 in

The how-to magazine of electronics

ELECTRONIC
Servicing & Technology

This *exclusive* monthly column will show you how to run your service operation more efficiently and profitably.

You'll learn about

- building customer satisfaction
- writing service contracts
- marketing your services
- hiring technicians.

Presenting an affordable Light Box System.

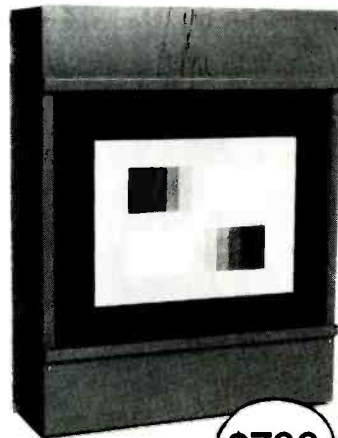

\$799

The method most manufacturers recommend

Model TR100 CB
Camera Light Box
with (2) transparencies

- (2) 3200^o Kelvin Lamps (meets mfr. spec.)
- 1-year conditional guarantee
- Transparencies mounted in acrylic with optical scratch-resistant surface
- 11-step gray scale transparency
- 7-Bar color transparency
- All orders are shipped within 72 hours, U.P.S.

KUTRONIX (313) 939-2740



P.O. Box 77103 • Sterling Hts., MI 48077



Circle (17) on Reply Card

Interfacing computers to the analog world—Part VI

By Joseph J. Carr, CET

The first few parts in this series have described analog-to-digital (A/D) and digital-to-analog (D/A) converters. Last month we looked at some practical data converters. This month we'll look at some methods for converting I_o to an output voltage with a low output impedance.

Last month we ended Computer Corner with a data converter circuit that worked by using two resistors as current-to-voltage converters. The problem with this circuit was that it had a high source impedance. We can solve that problem with the circuits discussed in this installment of Computer Corner.

Figure 1 shows a simple method for converting I_o to an output voltage (V_o) with a low output impedance (less than 100Ω) by using an inverting follower op-amp. The output voltage is simply the product of the output current and the negative feedback resistor: $V_o = R \times I_o$. As in the case described last month, a $5,000\Omega$ resistor will produce a $9.96V$ output voltage when the DAC-08 is set up for TTL inputs and $2.0mA$ I_o (max).

The frequency response of the DAC circuit can be tailored to meet circuit requirements. The normal output waveform of the DAC is a staircase when the input ramps up from 00000000 to 11111111 in a monotonic manner. If we want to make it an actual ramp function, we need to low-pass filter the output to remove the "stepness" of the normal waveform. An optional capacitor in shunt with feedback resistor R will offer limited (but useful) filtering on the order of $-3dB/octave$ above a cut-off frequency of $F = 1,000,000/(6.28RC)$, where F is the $-3dB$ frequency in hertz, R is in ohms and C is in microfarads.

In most practical circuits, you know

the value of F from the application. It is the highest-frequency Fourier component in the input waveform. We then need to calculate the value of the capacitor needed to achieve that cut-off frequency, so we would swap the F and C in the equation above: $C(\mu F) = 1,000,000/(6.28RF)$.

A related method shown in Figure 2 produces an output voltage of the opposite polarity from that of Figure 1. In this case, we merely take the circuit shown last month and connect a non-inverting unity-gain follower at the output. The output voltage is the product of I_o and R_2 . If we need a higher output voltage, we would use the circuit variant shown in Figure 2. In this case, the output amplifier has gain, so the output voltage would be:

$$V_o = (I_o \times R_2)(R_3/R_2 + 1).$$

One of the ways to achieve bipolar

binary operation is shown in Figure 3. In this case, the output amplifier is a dc differential amplifier and both current outputs of the DAC-08 are used. The output voltage and the corresponding input codes are shown in the table in Figure 3. Note that the maximum and minimum voltages are positive and negative. The zero selected can be either (+)zero (+1-LSB voltage) or (-)zero (-1-LSB voltage). It cannot be exactly zero because an even number of output codes are equally spaced around zero. In other words, the absolute value of $FS(-)$ is equal to the absolute value of $FS(+)$. There are also circuits that make zero = zero, but at the expense of uneven ranges for $FS(-)$ and $FS(+)$.

A practical bipolar DAC circuit

A practical circuit is shown in Figure 4. This circuit combines the circuit fragments shown earlier to make a complete circuit that can be used in real

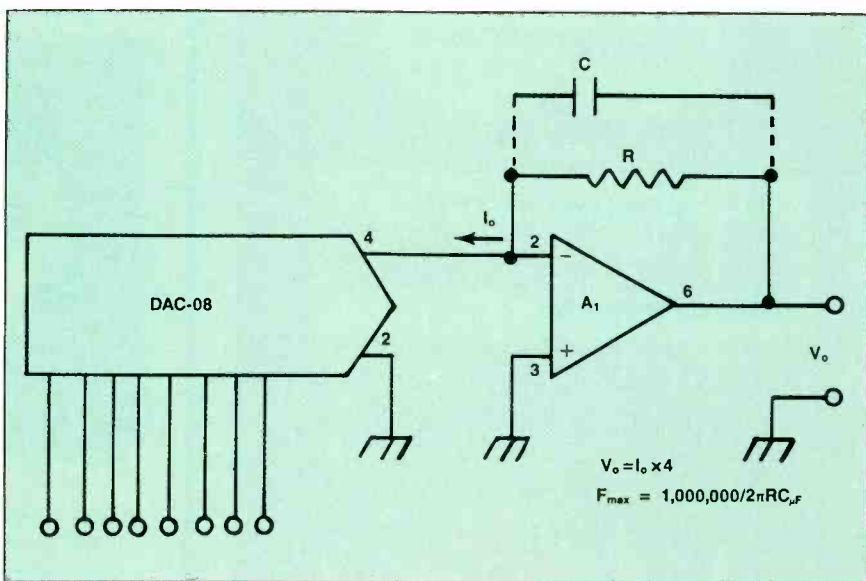

Figure 1. A simple method for converting I_o to an output voltage (V_o) with a low output impedance (less than 100Ω) is to use an inverting follower operational amplifier. The output voltage is simply the product of the output current and the negative feedback resistor: $V_o = R \times I_o$.

Carr, an electronics engineer, has published several books on electronics and is a frequent contributor to ES&T.

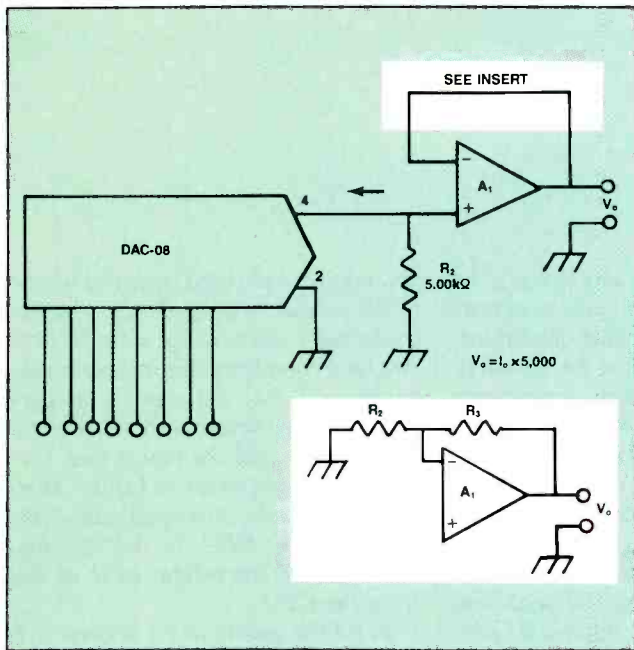

Figure 2. Another method for converting I_o produces an output voltage of the opposite polarity from that of Figure 1. In this case, we merely take a practical data converter and connect a non-inverting unity-gain follower at the output. The output voltage is the product of I_o and R_2 . If we need a higher output voltage, we would use the circuit variant shown in Figure 2. In this case, the output amplifier has gain, so the output voltage would be: $V_o = (I_o \times R_2)(R_3/R_2 + 1)$.

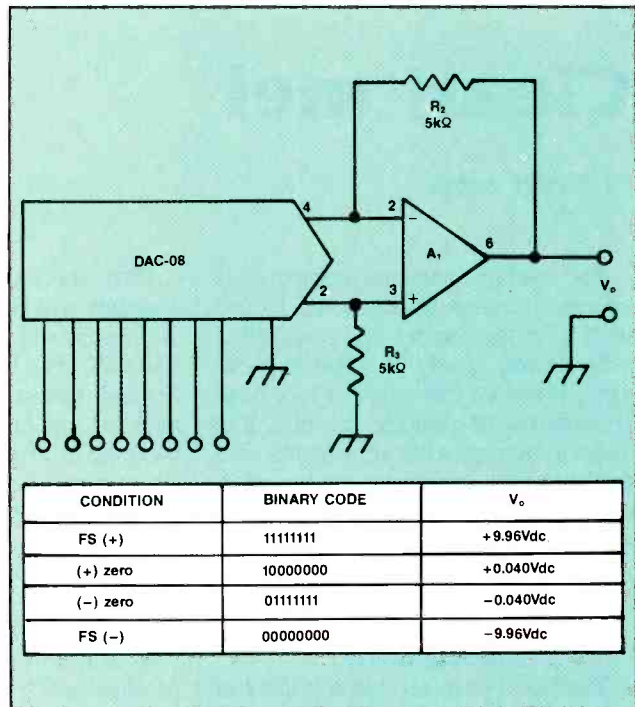

Figure 3. One of the ways to achieve bipolar binary operation is shown here. In this case, the output amplifier is a dc differential amplifier and both current outputs of the DAC-08 are used. The output voltage and the corresponding input codes are shown in the table.

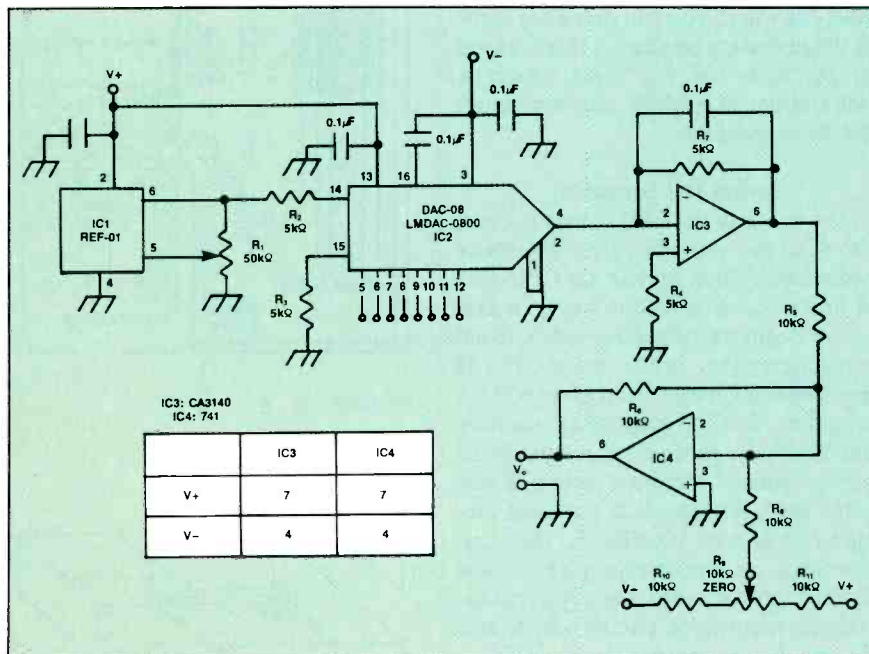

Figure 4. This practical bipolar DAC circuit combines the circuit fragments shown earlier to make a complete circuit that can be used in real situations. The heart of this circuit is a DAC-08 or LMDAC-0800 connected in the bipolar binary circuit discussed above. The reference potential is a REF-0110.000V IC reference source. Potentiometer R_1 adjusts the value of the actual voltage and also serves as a full-scale adjustment for the output voltage V_o . Potentiometer R_9 acts as a zero adjustment for V_o . The capacitor across R_7 limits the frequency response to 200Hz (with the value shown).

situations. The heart of this circuit is a DAC-08 or LMDAC-0800 connected in the bipolar binary circuit discussed above.

The reference potential in Figure 4 is a REF-01 10.000V IC reference source. Potentiometer R_1 adjusts the value of the actual voltage and also serves as a full-scale adjustment for the output voltage V_o .

The output amplifier (IC4) can be a 741-class op-amp or any other form; the need is not critical. Potentiometer R_9 acts as a zero adjustment for V_o . The capacitor across R_7 limits the frequency response to 200Hz (with the value shown). This limit can be changed with the equation given earlier.

Adjustment

1. Set the binary inputs all LOW (00000000).
2. Adjust R_9 for $V_o = 0.00V$.
3. Set all binary inputs HIGH (11111111).
4. Adjust potentiometer R_1 for $V_o = 9.96V$.

Next month, we'll take a closer look at A/D converters.



Clean me!

By Filbert Arzola

The average personal computer is equipped with a turbo mode, loaded with a lot of memory and compatible with a wide variety of software packages. However, this valuable tool rarely receives the periodic cleaning that keeps it running. After all, who has time these days to clean their computer? A computer should be properly cleaned and maintained at least once a month. Just what can happen to a computer that is not cleaned at least twice a year?

Avoiding disaster

There are two major disasters that can result from improper cleaning and maintenance. The first is that dust, hair, paper and other foreign objects can prevent proper air flow through the inside of the system, which can allow excessive heat to remain in the CPU and possibly cause the printed circuit boards to crack and short-circuit the computer. Moreover, semiconductor devices can excessively overheat and fail, causing a tidal wave of multiple failures throughout the system.

The second disaster begins with a dirty disk drive read/write (R/W) head, which can damage the head, the floppy diskette or the disk drive. How? The R/W head is very sensitive to dust particles. If particles collide with the R/W head while the head is moving, the head and the diskette may get scratched.

Because of these two glaring situations and their probability of occurring given the circumstances, every computer should be cleaned and maintained periodically, preferably once a month. To keep the computer clean, you only need to clean the inside and outside of the CPU and the outside of the monitor and the keyboard. Before we start, however, there are several important facts and safety precautions and some considerations as to the supplies used to clean the computer.

Arzola is an electrical and computer engineer and a computer hobbyist.

First, check the warranty to see if the warranty will be voided if the computer is opened, and under what conditions. Most PCs can be opened for cleaning. Second, observe all safety precautions such as unplugging the unit before cleaning it, working in a cool area, etc. These precautions are usually listed in the operator's guide, so take some time and read them. Third, study Figure 1, which shows which boards and what areas you'll be working with and how to clean them. Finally, remove all jewelry. This will eliminate one source of potential electrical shock.

The supplies needed to completely clean a PC include a PC cleaning kit, a cleaning program, a small PC vacuum cleaner, assorted hand tools and a soft pink pencil eraser. These products are readily available from most electronic or computer stores. (See the sidebar to find out where you can purchase some of the necessary products.) If you intend to purchase and use these products, don't forget to read the user's manuals for these products.

Inside the computer

The inside of the CPU is easy to clean provided that you patiently follow these procedures. First, remove the CPU cover and place it out of the way in a safe place. Begin your cleaning with a visual inspection of the inside of the CPU. If the computer hasn't been cleaned in a long time, don't be surprised to see dust tumbleweeds, paper clips and pieces of paper scattered all about inside. If this is the case, remove all of the large foreign matter with your hands, then use the small vacuum to eliminate the top layer of loose dust that usually accumulates on the printed circuit boards and on any uncovered surfaces of the CPU. Use the vacuum rather than blowing to remove the dust. The vacuum will keep the dust from spreading.

Allow any swirling dust to settle and remove the option cards one by one, gently pulling upward on both ends. As

you remove each card, visually inspect it for cracks, damaged runs, burned components and anything unusual. Once you have completed this inspection and determined that the card is in good shape, gently scrub both sides of the card contacts with the pink eraser, leaving the contacts clean and shiny. Place the option cards component-side down away from the CPU on another table. Then remove the bottom layer of dust from the CPU.

To rid the system of the bottom layer of dust requires the removal of the system board and the disk drives. Note that if the system contains a hard drive, you should make sure to park the heads before removing it from the system. Care-

FIGURE 1A

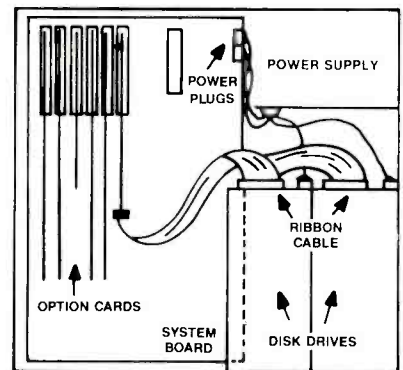

FIGURE 1B

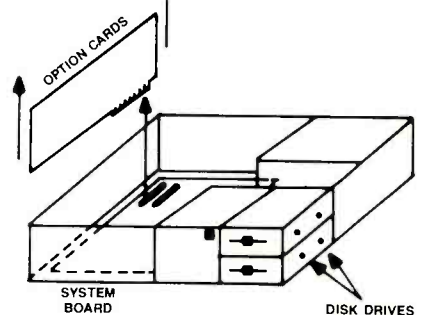

Figure 1. Figure 1A shows the top view of the computer; Figure 1B shows how the parts relate to one another. Carefully remove and clean each part as described in the text.

fully detach all power plugs and any ribbon cables from the system board and the disk drives. Remove the disk drives by removing the retaining screws from the sides, as shown in Figure 1, and pulling them forward and out of the system. Handle them carefully, inspect them for dust and damage, and place them on a flat surface. Next, carefully slide the system board out to the left and visually inspect it. Clean it with the small vacuum and place the board component-side up next to the option cards. Use the vacuum to remove the remaining layer of dust inside the CPU.

Replace everything back into the CPU

Suppliers of computer cleaning tools, software and supplies

Perfect Data Micro Maintenance Kit
Innovative Computer Products
18360 Oxnard St.
Tarzana, CA 91356
213-996-4911

This kit is a general-purpose cleaning kit for use on computers, terminals, word processors and peripherals. The cleaning diskette comes in both 5-inch and 3-inch versions.

System Sweeper PC/printer vacuum
Microcomputer Accessories
5405 Jandy Place
P.O. Box 66911
Los Angeles, CA 90066-0911
213-301-9400 (CA) or 800-521-8270 (outside CA)

The System Sweeper, model 440, is a compact unit that will let you get into those hard-to-reach places.

Test Drive utility
Microsystems Development
4100 Moorpark Ave., #104
San Jose, CA 95117
408-296-4000

The Test Drive utility enables the user to clean disk drives, while other utilities included perform other diagnostic checks of the disk drives. This disk is available for the IBM and can check 360K, 720K, 1.2M and 1.44M disk drives.

in the order in which it was removed. Be careful not to force, bend or crack any of the printed circuit boards. Once you have reinstalled everything, you are ready to clean the floppy disk-drive R/W heads.

The heads are simple to clean. First, make sure all of the disk drive plugs and the ribbon cables are properly connected to the system board and the disk-drive cards. Slide the CPU cover back on the unit and plug in the power cord. Turn on the computer and use disk drive A to boot the system.

Place the cleaning program disk in drive B. The cleaning program will allow a selected drive to spin continuously for twenty seconds. Set the program to clean drive A and remove the system disk. Insert a prepared cleaning diskette into drive A and run the program. This process will remove most of the particles on the heads. Once drive A is cleaned, set the computer to clean drive B, insert the prepared cleaning diskette and run the program.

Outside the computer

Cleaning the inside of the computer shouldn't have been any problem for a competent technician. Cleaning the outside is even easier. First, switch off and unplug the system. Place some cleaning solution on a cloth and clean all of the plastic and metallic outer surfaces of the CPU and monitor. (Note: The cleaning solution can be substituted with a mixture of water and mild detergent.) Don't spray the cleaning solution onto any of the surfaces. Also, the cleaning cloth you use should only be slightly damp. Be careful not to get any moisture into any of the vents, and don't press too hard on any of the surfaces. Next, use a clean, non-abrasive cloth and some video-screen cleaning solution to clean the monitor screen.

The keyboard can be cleaned in two steps. First, use the vacuum to remove any hidden dirt from between the keys. After you are finished vacuuming, use a cloth and some cleaning solution and clean the rest of the keyboard. If some of the built-in dirt is on the side of a key and difficult to reach, use a foam-tipped cleaning wand and some cleaning solution to wipe away the grime.

All that's left to do is plug in the power cords and prepare the system for future use.

ES&T

Now You Can Learn Electronics
From VHS Video Tape!!!
UCANDO Now Has Four Video
Tapes Designed For The
Electronic Enthusiast.

ELECTRONICS AND YOU—PART ONE DC

PRICE \$32.95

You will learn about Series circuits, Parallel circuits, the combination of Series-Parallel circuits, Ohms Law, Voltage, Current and Resistance as well as how to use the Digital multimeter.

ELECTRONICS AND YOU—PART TWO AC

PRICE \$32.95

You will learn about AC theory, Coils Transformers, Capacitors, Filter circuits and how they are used in actual circuits.

VCR MAINTENANCE AND REPAIR

PRICE \$32.95

This tape was designed for the average VCR user. No special tools or schooling are required for this tape. You will learn how to clean the entire tape path in the VCR as well as how to replace some of the belts in the VCR.

INTRODUCTION TO VCR REPAIR

PRICE \$59.95

You will learn how the VCR Processes the Luminance, Chromance and Audio signals in the VCR, in both the playback and record modes, you will also learn about the Servo systems used to control the Capstan motor and the Video Drum Cylinder. This tape also covers many more aspects of the VCR.

ORDER YOUR TAPES NOW!

VISA and MASTER CARD are accepted.

CALL: (513) 548-6113 or mail check or money order top:



P.O. Box 386
Greenville,
Ohio 45331

Circle (19) on Reply Card

ATTENTION TECHNICIANS

- ★ JOB OPENINGS
- ★ MONTHLY TECHNICAL TRAINING PROGRAM
- ★ BUSINESS MANAGEMENT TRAINING
- ★ LOW COST INSURANCE
- ★ CERTIFICATION
- ★ TECHNICAL SEMINARS

All of this in a nonprofit international association for technicians

FIND OUT MORE:



604 N. Jackson St.
Greencastle, IN 46135
317/653-8262

Readers' Exchange

Editor's Note: Readers' Exchange items are published in the order they are received. We are happy to offer this service at no charge to you, our readers, but we ask that:

- Items are typed (or legibly written).
- You include your name and address on the same page as your ad (envelopes and contents are often separated). Please also include your telephone number (specify if you don't want it published). Using your peel-off label is a good idea.
- You limit any ad to no more than three items. If space demands, ads will be edited to roughly four lines in the magazine.
- Mail to: Readers' Exchange, Electronic Servicing & Technology, P.O. Box 12901, Overland Park, KS 66212.

Please remember that ES&T is in production six weeks to two months ahead of publication date.

WANTED

50MHz or higher scope, dual-trace, triggered sweep with two probes and manual. Give your low price for it. *John Waskowitz, 580 83rd St., Brooklyn, NY 11209.*

Complete set of Diehl technician/shop owners Newsletter and ES&T magazines (1972-1986). *Craig Thumme, 1421 Jackson SE, Saginaw, MI 48602; 517-799-8561.*

Remote control receiver used in AMI model XJDB-200 (CONTINENTAL 2) jukebox. Unit consists of AMI parts R-1895A(B) relay panel and R-1896 stepper assembly (both are needed, any condition OK). Also need service data for this unit. When installed, unit allows remote wallbox operation. *A. Ford, 1238 Academy St., Scranton, PA 18504.*

Tube chart, operating manual and schematic for Radio City Products model 801 M tube tester-set tester. *James Kovar, 2001 N. 73, Lincoln, NE 68505.*

Vertical output transformer for Quasar chassis TS959, part number TLV6253. Quote price. *Bill Risko, 1329 Twining Road, Dresher, PA 19025; 215-659-2349.*

Updated tube checking chart for Mercury tube tester model 1100, made by Mercury Electronics, originally of Mineola, New York. Charts needed are for tubes for modern color TV and radio. I also have old radio tubes (80, 50, 2A3, etc.). *W. Hartman, c/o The Hub Cap Place, 3005 Douglas Street, Victoria, B.C., CANADA V8T 4N2.*

Original manufacture "Radio Service Manuals," approximately 1950 and older. Companies such as Capehart, Scott, Stromberg Carlson, Sparton, Fada, Westinghouse and others. Also want to buy old original radio IF and power transformers, dials and miscellaneous old radio items. *Wilford Wilkes, Box 103, Brisbin, PA 16620; 814-378-8526.*

Schematic or service manual for Tu Sharp model C19656. Send price. *Ram TV Service, San Vicente 4E, Mayaguez, Puerto Rico 00708.*

Service information on Philco model 8300 pre-amp and Sprague model TO-5 cap tester. *Leo E.*

Smith, P.O. Box 945 Vet Home Sect. J, Yountville, CA 94599.

Schematic diagram for Sony stereo receiver model STR6050. Will pay for manual, copying and mailing costs. *Dominick Charowsky, D.C. Video Electronics, 610 Harding Road, Browns Mills, NJ 08015-3705; 609-893-3853.*

Complete or partial cabinet, remote control TRT-13 (or -14) and miscellaneous small parts for QUASAR (Wards) 19-inch TV chassis ACTS-959S ("Supermodule"), Quasar model TT5819NW (Wards unknown); Sanyo F-0219 flyback; GE EP77X35 flyback unit. *Dave Christel, 219 Shady Lane, La Crosse, WI 54601; 608-782-1508.*

Sencore VA48 or equivalent that will generate high voltage to test solid-state flyback and tripler in sets. Very reasonable. *Murray's Repair Service, 8842 Grange Hill Road, Sauguoit, NY 13456; 407-586-5932.*

Service manual, schematics and all other available information for Measurements Corp. model 803A FM signal generator. Copy is OK. Please state price. *Kirk Ellis, 18 Foxfire, Selma, NC 27576; 919-965-9577.*

Persons interested in forming a user's group to evaluate, use, develop and promote computer-aided instruction in the field of electronics. *Jim Peck, 207 E. School St., Kent, OH 44240; 216-678-4611.*

TRS 80III 16K to 48K conversion/expansion information; old TRS 80 for parts; service data for AKAI model VTR VT110 videotape recorder and model VC110 camera. *N. Young, 214 E. Robertson St., Brandon, FL 33511.*

Service data or address of supplier for "Conic" brand TV, model T7711D (tag says manufactured for Far East United Electronics, Ltd., 171 Hoi Bun Road, Kwun Tong Kowloon, Hong Kong). *Chapman TV, 3601 West Eighth Street, Cincinnati, OH 45205; 513-471-6211.*

AN245 and AN331 ICS (ECG and SK replacements no longer available); schematic for JVC model 4VR-5426X stereo. *Stievers TV, 6819 Wilamette, Austin, TX 78723; 512-926-7479.*

Schematic for General Interface Systems model PC-400 uninterruptible power supply. *Dan Ogle, P.O. Box 74, Gabbs, NV 89409.*

Service data VM R/R Tape Rec./Plyr. Model 780 AV; service data and/or operating manual (computer) Texas Instruments "Series 700" model 770 Intelligent Terminal. *Wade Nelson, 22687 Miriam Way, Grand Terrace, CA 92324; 714-825-2287.*

Working RCA CTC140B chassis, top price paid; RCA IHVT 145722 (for CTC 97C chassis). *C.G. Owens, Charles TV, Route 210 & Poplar Lane, Indian Head, MD 20640; 301-743-7777.*

Philco Predicta items: parts, ads, sets, etc.; Radio Retailing magazines. *Doug Heimstead, 1349 Hillcrest Drive, Fridley, MN 55432; 612-571-1387.*

Schematic and instruction book with any additional mod notes for B&K model 1077B television

analyst. Will pay postage for original both ways or a copy will do. *Marvin Moss, P.O. Box 28601, Atlanta, GA 30358; 404-494-5357, days.*

FOR SALE

SAMS Photofacts #679 to #1905, from \$3 to \$4.50 each, send for complete list; instruction manual and schematics for Dumont type 403 and 403-A oscilloscopes. Make offer. *William J. Maida, 274 W. Sabal Palm Pl., Longwood, FL 32779; 407-869-6138.*

B&K 1076 analyst, no slide or probes, \$75; Viz WR50C solid-state RF signal generator, \$85; Eico 443 solid-state semiconductor curve tracer, \$50; Sencore model SM152 sweep and marker with probes, \$75; Eico model 460 wide-band scope, works but I believe needs a bit of service, \$50. Add shipping on all. *Stanley Chalker, Kodac Retina SVC, 1176 Smithsonia Ave., Youngstown, OH 44505.*

VA-48 TV and video analyzer, excellent condition, \$600. *Angelo Alessi, 29 Cross St., New Windsor, NY 12550; 914-562-9152.*

10J106B test jig with focus control, \$200; Tele-matic JG775 sub tuner, \$40; Viz WTS540B leakage tester, \$20; Fluke 77 with 80K6 high-voltage tester, new in box, \$110; Diehl Mark V, dismantled for parts, \$50; Transcat short finder, new, \$30; complete NTS FCC course, \$200. *Orland Lynd, 2300 Harvard Way #124F, Reno, NV 89502; 702-825-6157.*

Russian scope, dual-beam, full featured, English front panel and manual, plus spare parts kit, in good condition, ideal for ham use, \$350. *J. Snaper, Box 5948, APO New York, NY 09633.*

Rebuilt and tested Zenith and RCA modules. Asking dud price. Send SASE. *G. Stuart Electronics, 503 Sunnyside Lane, Hopkins, MN 55343.*

RCA 106A, Zenith 800-880 and Sylvania CK3000 jigs and hundreds of adaptors, all for \$500 plus shipping; Sound Technology 1000A FM alignment generator, \$1,500; new Magnavox modules or tuners, 50% of NAP cost (call for availability). *Electronic Services, 5814 Industrial Road, Fort Wayne, IN 46825; 219-484-3326.*

Tekfax/Profax numbers 1584 through 2099, 3000 through 3014, Tekfax 112 and 114—best offer; many used tubes in A-1 condition, various sets of SAMS folders. Send SASE for lists. *M.B. Gemballa, Mitchell Electronics, 4 Golf Ave., Maywood, NJ 07607.*

B&K model 415 sweep and marker generator, in good condition with leads and instruction manual, \$110; Sencore SS137 sweep circuit analyzer, with manual and leads, \$55. *Lurry, 619-462-7445.*

Zenith system analyzer for X1 & Z chassis, with print and instructions, in original Zenith case, \$30 plus shipping; Sylvania CK3000 w/TA3000 test jig plus over 20 adaptors, small burnt spot in tube, \$49 plus shipping. *M.E. Andrews, P.O. Box 91, Exeter, RI 02822.*

New B&K 467 CRT, rejuvenators; yoke/flyback

tester with high-voltage probe (never used); Beckman Tech 300 digital multimeter 100, s.stk.; audio IC chips and transistors, etc. Best offer. *Abdul A. Salim, 2085 Anthony Ave., Bronx, NY 10457.*

Sams #1 to current and 140 assorted AR, CB & etc. books. Make offer. *Alliance TV, 705 Main, Concordia, MO 64020; 816-463-7355.*

Zenith 800-1080 bench jig, 34 adapters for last 8 years of Zenith, Quasar, RCA & Sylvania, new condition, \$245; Sencore VA-48 video analyzer, all accessories and documentation, excellent condition, \$500; 700 SAMS Photofacts (#1000 to #2550), most in new condition, \$525. *Clark Electronics, Route 2 Box 155, Bogue, KS 67625; 913-839-4333.*

Tektronics 541A scope with CA dual-trace plug-in, not working, make offer; Tektronics 561 scope with type 50 and 51 plug-ins, not working, make offer; Heathkit IO-4550 dual-trace 10 MHz scope, good condition, \$125; two Bell & Howell scopes, \$35 each; Leader LBO505 dual-trace scope, \$200. *H. Sievers, 6819 Willamette Drive, Austin, TX 78723; 512-926-7479.*

Eico model 950B res/cap comparator, \$45; RCA WR-64B color bar/dot/crosshatch generator, \$50; Heathkit model LG-1 lab generator, \$50; Heathkit model 0-II lab scope (as is, CRT OK), \$50; Heathkit model S-3 electronic switch (for dual-scope

reading), \$35. Manuals included. *Home Electronics, 69 Main St., Greenwich, NY 12834; 518-692-9336.*

Rebuilt 25AXP22 color picture tube in original sealed carton, \$50 plus shipping; B&K model 415 sweep/marker generator with leads and manual, \$300 plus shipping. *E.H. Frazier, R.R. #8 Box 632, Brownsville, TX 78520; 512-542-1960.*

Many, many TV parts, guaranteed and 50% off wholesale. Send SASE for parts needed. *Gary Barzily, 84-39 120th St., Kew Gardens, NY 11415; 718-847-7965.*

Mercury model 990 tube tester with manual, good condition, \$30 plus shipping; EICO model #1140 series-parallel resistor-capacitor combination box with manual, good condition, \$40 plus shipping; Sams photofact sets #69 through #496, \$1 each or all 275 sets for \$100 plus shipping. *John Brouzakis, 247 Valley Circle, Charleroi, PA 15022; 412-483-3072.*

Make an offer. Volumes of Howard W. Sam's Photofacts dating from 1946, plus several volumes of Trouble Shooter's manuals from 1936. *Dorothy Imgrund, 513 E. 28th St., Brainerd, MN 56401; 218-829-9315.*

Sencore equipment: VA62, VC63, CR70, LC53 and SC61, all in good condition, \$5,000; Diehl

Mark III scanner, \$250. *Bill Creel, 16047 Forzando Ave., Brooksville, FL 34609; 904-796-7654 after 5 p.m.*

Nearly complete Sams Photofacts to #2536; other manufacturers' service data; test equipment; parts inventory. Send SASE for list. *David A. Day, Flori-Day Electronics; 44 Avenue E., Apalachicola, FL 32320; 904-653-9637.*

Complete TV repair facility. Many Heathkit. Call or write for details. *J. Bonner, 411 Pine Lake Road, Boiling Spring Lakes, Southport, NC 28461; 919-845-2881.*

Sencore CR-143, like new, \$100; Sencore TRC4, like new, \$30; H.P. universal bridge, \$100; B&K model 606 tube tester, \$55; Heathkit I-101 vector scope, dot bar Generator, \$100. *Harley W. Jansen, 1600 First Ave., Marion, IA 52302; 319-377-0076.*

Oscope Tek 585A/W 82 plug-in and manual, (calibrated) 95MHz, \$500 or best offer, plus UPS. *Major A. Meckling, 21 Oak Grove Ave., Springfield, MA 01109; 413-736-8641 after 4 p.m., weekends OK.*

New Diehl Mark V tester, \$325; new Diehl Mark IV tester, \$300; new Diehl Mark III tester, \$150. Add shipping. Free electronic course material with order. *Geo Reed, 817 Underhill Ave., Mamaroneck, NY 10543; 914-381-4536.*

ES&T

Classified

Advertising rates in the Classified Section are \$1.55 per word, each insertion, and must be accompanied by payment to insure publication.

Each initial or abbreviation counts as a full word.

Minimum classified charge \$30.00.

For ads on which replies are sent to us for forwarding (blind ads), there is an additional charge of \$35.00 per insertion to cover department number, processing of replies, and mailing costs.

Classified columns are not open to advertising of any products regularly produced by manufacturers unless used and no longer owned by the manufacturer of distributor.

FOR SALE

TV TOUGH DOGS: 300 symptoms and cures. Send \$7.95 to DAVIS TV, 11772 Old Fashion Way, Garden Grove, CA 92640. 10-87-tfn

SONY-TRINITRON Rebuilt Picture Tubes are now available. All tubes shipped U.P.S. No Charge. We buy all Sony duds. Rochester Kinescope, 716-235-0750. 11-87-tfn

MODERN PHOTOCOPIER REPAIR: Expand knowledge into high profit area. Troubleshooting, tech tips, parts markup, etc. Illustrated. \$34. 5615 Deer Creek Drive, Ferndale, WA. 98248. 11-88-11

VHS-VCR REPAIR SOLUTIONS VOLUMES I, II, III. Each contains 150 symptoms and cures, cross reference chart, free assistance. Each \$11.95, any two \$19.95, all \$29.95. Eagle Electronics, 52053 Locks Lane, Granger, IN 46530. 5-88-tfn

OSCILLOSCOPE—Sencore SC61 waveform analyzer, brand new, never used, in warranty, in orig. ctn. List \$2,995. \$2,200 negotiable. Electro-Tech (504) 928-4073. 11-88-11

FOR SALE New Sencore test equipment; 1-FS74 Channelizer SR; 1-TF46 Super Cricket Transistor & FET Tester; 1-LC75 Z-Meter; 1-FC71 GHz Frequency Counter; 1-CR70 Universal CRT Analyzer & Restorer; 1-PR57 Variable Isolation Transformer; 1-VA62 Video Analyzer; 1-VC63 VCR Test Accessory; 1-NT64 NTSC Pattern Generator; 1-SC61 Waveform Analyzer, 60hz; 1-TP212 Probe, 10hz; 1-39G81 Probe, Demodulator, 250Mhz; 2-NP229 Scope Needle Point Adaptor. Any reasonable offer. Rick Connolly, P.O. Box 610, Monticello, UT 84535, 801-587-2040 or -2937. 10-88-21

CB RADIO REPAIRS/MODIFICATIONS: Books, plans, kits, high-performance accessories since 1976. Catalog \$2. CBCI, Box 31500E, Phoenix, AZ 85046. 10-88-41

ALMOST NEW SENCORE VA63 video analyzer, NT64 VCR test accessory, VC63 color generator. \$3,500.00. Sams Photofacts 1000-2095 plus 100 other brand service manuals—RCA, NPA, etc. Best offer. Call (916) 836-0838 or (415) 967-5443. 11-88-11

SENCORE VA48, excellent condition, \$595.00; CR70 beam builder, sells new for \$1,299.00, asking \$595.00; model DVM38 Sencore digital volt-ohm-milliammeter, \$95.00; Sencore X-STR tester model TF46, \$275.00; Call evenings after 6:00, 1-801-487-8742. 11-88-11

COMPUTER TV/VCR REPAIR TIPS DATABASE PROGRAM (IBM Compatible w/hard drive). Scan symptoms and cures by model or chassis. Add, change, delete, print out. \$49.95 for program. \$69.95 includes database with over 1,000 up-to-date repair tips. Add \$2.50 postage and handling. Computer Assistance, Box 232026, Anchorage, AK 99523. 11-88-31

INTEGRATED CIRCUITS—Lowest prices on Admiral, G.E., NAP, Philco, RCA, Sears, Sylvania and Zenith types. Write PEC, Box 894, Union, N.J. 07083. 11-88-41

PHOTOFACTS: Folders under #1400 \$4.00. Above #1400 \$6.00. Sent same day first-class postpaid. Loeb, 414 Chestnut Lane, East Meadow, NY, 11554. 9-88-31

TV/VCR REPAIR TIPS VOLUMES I AND II. Each with 1,000 up-to-date problems/cures listed by model and chassis for quick easy lookup. \$29.95 per volume. Add \$2.50 postage and handling. Computer Assistance, Box 232026, Anchorage, AK 99523. 11-88-31

BUSINESS OPPORTUNITIES

TV/VCR SERVICE: Southern New Jersey, includes Real Estate. Well established, fully equipped. Excellent financial opportunity. Price negotiable. Owner retiring. PO Box 46, Salem, NJ 08079. 11-88-11

Moving?

Take us with you.

Just peel off the subscription mailing label and attach it to the address change card located at the front of this issue. Please allow 6-8 weeks to process your address change.

WE'RE THE ONE . . .

- With over 12,000 Electronic Products
- With LOW Prices & Volume Discounts
- With the PRB LINE of Replacement Belts & Tires

Call Toll FREE

1-800-558-9572 in Wis. 1-800-242-9553

24 HOUR ORDERING: FAX: 414-473-4727

"First in Quality And Service"

PRIME

ELECTRONICS CO.

P.O. Box 28 • Whitewater, Wisconsin 53190

Circle (22) on Reply Card



"Tech's Guide To Pricing"
updated new 5th edition... a framework for setting rates that apply to Hi-Tech products... a formula that guarantees SUCCESS!
Call Toll Free for details
1-800-228-4338 8/5 CST

Circle (26) on Reply Card



HAND REMOTE REPAIR
LA GUARDIA ENT
5882 Rich Hill Way
Yorba Linda, CA 92686
(714) 579-1276

- Call for pricing
- 24 hr. turnaround time
- Return freight pre-paid

90 Day Warranty
New Battery Included

Circle (21) on Reply Card

NEW LOW PRICE \$39.95

TEST/CLEAN/RESTORE with a UNIVERSAL CRT ADAPTER that fits all CRT testers and quickly hooks-up to all CRT's on the market (now or in the future). Guarantees profit & total CRT servicing. Used by TV Repair, US Govt., Airlines, Computer Serv., Dept. of Defense, Patented Adaptor-Sockets-CRT Reference/Setup book—Only \$39.95 plus \$2.50 postage & handling. Our 6th year. Over 15,000 sold, Chargecards/Checks/COD. Money Back Guarantee.
FREE CALL 1-800-331-9658
DANDY MFG. CO.
2323 Gibson St. Muskogee, OK 74403

Circle (20) on Reply Card



Moving?

Take us with you.

Just peel off your subscription mailing label and attach it to the address change card inside this issue. Please allow 6-8 weeks to process your address change.

Ad Index/Hotline

Company	Page Number	Reader Service Number	Advertiser Hotline
Beckman Industrial Corp.	IFC	1	619/495-3200
C + S Sales	45	14	800/292-7711
Chemtronics, Inc.	21	11	800/645-5244
Consolidated Electronics Inc.	59	18	800/543-3568
Consumer Electronics Show	1	3	
Dandy Mfg. Co.	68	20	800/331-9658
ETA	65		
Fluke, John Mfg. Co., Inc.	5	5	800/227-3800
Fluke, John Mfg. Co., Inc.	13	7	800/227-3800
Global Specialties Corp.	51	15	800/345-6251
Hitachi Sales Corp. of America	25	8	516/921-7200
ISCET	59		
Kenwood Test & Measuring Instruments	41	12	213/639-4200
Laguardia Enterprises	68	21	714/579-1276
Leader Instrument Corp.	3	4	800/645-5104
MCM Electronics	55	16	800/543-4330
NESDA	55,57		
Parts Express Int'l Inc.	43	13	513/222-0173
Philips ECG	19	10,24,25	800/225-8326
Prime Electronics	68	22	414/473-4727
PTS Corp.	17	9	812/824-9331
Sencore, Inc.	IBC	2	800/843-3338
Sperry Tech, Inc.	68	26	800/228-4338
Tektronix, Inc.	8-9	6	800/835-9433
Tektronix, Inc.	8A-8B		800/835-9433
Tronix, Inc.	61	17	313/939-4710
U-CAN-DO VCR Educational Products Co.	65	19	513/548-6113
Zenith	BAC		

ADVERTISING SALES OFFICES

ELECTRONIC

Servicing & Technology

KANSAS CITY, MISSOURI

Greg Garrison, Sales Manager

P.O. Box 12901

Overland Park, KS 66212

Phone: (913) 888-4664

Fax: (913) 888-7243

Telex: 42-4156 INTERTEC OLPK

OXFORD, ENGLAND

Nicholas McGeachin

Roseleigh House, New Street

Deddington, Oxford OX5 4SP

Phone: (0869) 38794

Telefax: (0869) 38040

Telex: 837469 BES G

TOKYO, JAPAN

Haruki Hirayama,

EMS, Inc.

Sagami Bldg., 4-2-21, Shinjuku,

Shinjuku-ku, Tokyo 160, Japan

(03) 350-5666

Telex: 2322520 EMSINCJ

Cable: EMSINCPERIOD

FREWVILLE, SOUTH AUSTRALIA

John Williamson

Hastwell, Williamson, Rep. Pty. Ltd.

109 Conyngham Street

Frewville 5063

South Australia

Phone: 799-522

FAX: 08 79 9735

Telex: AA87113 HANDM

With Just One Probe Hookup You Can Confidently Analyze Any Waveform To 100 MHz, 10 Times Faster, 10 Times More Accurately, Absolutely Error Free, Guaranteed Or Your Money Back . . .



**With The SC61 Waveform Analyzer
\$3,295.00 PATENTED**

Promises of increased productivity from other oscilloscopes fade fast when compared to the speed and accuracy of the SC61. Eliminate the confusing menus, cursors and complexity of regular oscilloscopes at the push of a button. Here's what the SC61 does for you:

Analyze Waveforms Easily

- Accurate Waveform Display - 60 MHz Bandwidth (usable To 100 MHz) To Test The Latest Digital Circuits.
- Rock-Solid Sync - ECL Logic Circuits And Differential Amplifiers Give Fiddle Free Operation.
- Four Times The Measuring Range - Measure From 5 mV To 2000 Volts (3000 Volts Protection) For Expanded Signal Handling.

Autotracking™ Digital Readings Analyze The Whole Signal

- Autoranging DC Volts Through Single Probe, Even With AC Coupled.
- Automatic Peak-To-Peak Volts - Even If Variable Control Is "Out Of Cal".
- Automatic Frequency Measurements Without Sensitivity Adjustment Or Range Switching.

Digital Delta Tests Analyze Any Part Of The Signal.

- Delta Peak-To-Peak Volts - Peak-To-Peak Volts Of Any Part Of The Signal.
- Delta Time For Any Time Reading - Including Delay Between Traces
- 1/Delta Time - Frequency Of Part Of The Signal - Finds Sources Of Interference Or Ringing.

Frequency Ratio Test - Tests Multiplier And Divider Circuits

Easy To Use - Human Engineered Controls And Virtually No Graticule Counting Or Calculations

The SC61 is designed to give you the measurements you need fast. We make one claim:

"Try the SC61 on your bench for 30 days. If it doesn't cut your present scope time in half, send it back for a complete refund, no questions asked."

Try the SC61 for 30 days, and discover true troubleshooting speed.

**Call 1-800-843-3338
In Canada Call 1-800-851-8866**

**For your own reputation
and in your customers' best interest
always insist on**

Genuine Zenith
Remanufactured Replacement Parts
Reconditioned and Serviced for Reliability
by Zenith People
as Knowledgeable and Dedicated as
Those Who Made the Originals!

One of the easiest, fastest, and surest ways for you to preserve the pedigree and maintain the quality of the Zenith products you service is with genuine Zenith replacement parts.

And at no time is this more critical than when you replace the more sophisticated components like modules, tuners, channel selectors and sub-assemblies.

Your participating Zenith parts distributor will supply you with a replacement remanufactured, reconditioned and serviced for reliability by Zenith people as dedicated and knowledgeable as those who made the original.

Equally important, the replacement module or sub-assembly you receive in exchange from your Zenith parts distributor

will most likely incorporate any Zenith factory-made modifications in effect at the time of remanufacture.

And nowhere else but in a participating Zenith parts distributor's Exchange Program can you get assurance that a replacement incorporates Zenith factory up-dates!

To learn the location of the Zenith R&R Exchange Counter in your area, write on your company letterhead and we will help you locate one that's nearby.

Risking an exchange for a Zenith replacement anywhere else doesn't make sense. Not when factory-fresh replacement modules and sub-assemblies are so readily available thru a Zenith parts distributor's Exchange Program! Write now!



The quality goes in before the name goes on.®

Zenith Service, Parts & Accessories • 11000 Seymour Avenue, Franklin Park, Illinois 60131 • A Division of Zenith Electronics Corporation